

**Paper Code: BCA 304**

**L T C**

**Paper ID: 20304**

**3 1 4**

**Paper: Mobile Computing**

**Pre-requisites: Knowledge of Digital Electronics (BCA 106), Computer Networks and Programming Concepts**

**Aim**

To provide basic knowledge on Wireless Communications, Mobile Internet and Mobile Content Services.

**Objectives**

- To learn the basics of Wireless voice and data communications technologies.
- To build working knowledge on various telephone and satellite networks.
- To build skills in working with Wireless application Protocols to develop mobile content applications
- To build practical knowledge on WML and WML Script

**INSTRUCTIONS TO PAPER SETTERS:**

**Maximum Marks: 75**

1. Question No. 1 should be compulsory and cover the entire syllabus. This question should have objective or short answer type questions. It should be of 25 marks.
2. Apart from Question No. 1, rest of the paper shall consist of four units as per the syllabus. Every unit should have two questions. However, student may be asked to attempt only 1 question from each unit. Each question should be 12.5 marks

**UNIT - I**

**Introduction to wireless communications:** Applications, Short History of Wireless Communications, Market of Mobile Communications. [T1]

**Elementary Knowledge on Wireless Transmission:** Frequency of Radio Transmission, Signals, Antennas, Signal Propagation: Path Loss of Radio Signals, Additional Signal Propagation Effects, Multipath Propagation, Multiplexing: Space Division Multiplexing, Frequency Division Multiplexing, Time Division Multiplexing, Code Division Multiplexing, Modulation: Amplitude Shift Keying, Frequency Shift Keying, Phase Shift Keying, Advanced Frequency Shift Keying, Advanced Phase Shift Keying, Multicarrier Modulation, Spread Spectrum: Direct Sequence Spread Spectrum, Frequency Hopping Spread Spectrum, Cellular Systems. [T1]

**[No. of Hrs: 11]**

## UNIT – II

**Elementary Knowledge on Medium Access Control:** Motivation for a specialized MAC, Hidden and exposed terminals, Near and far terminals, Introduction to SDMA, FDMA, TDMA: Fixed TDM, Classical Aloha, Slotted Aloha, Carrier sense multiple access, Demand assigned multiple access, PRMA packet reservation multiple access, Reservation TDMA, Multiple access with collision avoidance, Polling, Inhibit sense multiple access, CDMA, Spread Aloha multiple access, Mobile communications, Comparison of S/T/F/CDMA. [T1]

**Elementary Knowledge on Telecommunications Systems:** GSM: Mobile services, System architecture, Radio interface, Protocols, Localization and calling, Handover, Security, New data services, DECT: System architecture, Protocol architecture.[T1]

Elementary Knowledge on Satellite systems: History, Applications, Basics: GEO, LEO, MEO, Routing, Localization, Handover. [T1]

[No. of Hrs: 11]

## UNIT – III

**Mobile Internet:** Introducing the Mobile Internet, Services for the mobile Internet, Business opportunities.[T2]

**Implementing WAP Services: WML:** WML Variables and Contexts: Variable Substitution, Setting Variables, Browser Contexts, WML Tasks and Events, WML User Interaction: Problems with Web Interaction, Interaction in WAP, Elements: <input> , <select> ,<option> , <optgroup>, <do> , <anchor> , <a> , The tabindex Attribute, WML Timers, WML Decks, Templates, and Cards: Elements: <wml>, <head>, <access>, <meta> , <card> , <template>, WML Text and Text Formatting, Elements <p>, <br>, Character Formatting, Tables, WML Images: <img> Element, The WBMP Image Format. [T2, T3]

[No. of Hrs: 11]

## UNIT – IV

**WAP:** the Mobile Internet Standard, Making the Internet Mobile: Challenges and Pitfalls, Overview of the Wireless Application Protocol [T2]

**Implementing WAP Services: WML Script:** Datatypes, Variables, and Conversions, Operators and Expressions: Operand Conversions, Assignment Operators, Arithmetic Operators, Bitwise Operators, Shift Operators, Logical Operators, Increment and Decrement Operators, Comparison Operators, Type Operators, The Conditional Operator, The Comma Operator, Precedence and Associativity, WMLScript Statements: Expressions as Statements, Blocks of Statements, Conditions, Loops, Returning from a Function, Other Statements, WMLScript **Functions:** Function Declarations, Function Calls, Calls to Other Script Units, Calling WMLScript from WML, Standard Libraries, WMLScript Pragmas: The access Pragma, The meta Pragma, Elementary Knowledge on Libraries: Lang , Float , String ,URL , WMLBrowser , Dialogs [T2, T3]

[No. of Hrs: 11]

## UNIT - I

### Introduction to wireless communications: -

Wireless operations permit services, such as long-range communications, that are impossible or impractical to implement with the use of wires. The term is commonly used in the radio transmitters and receivers, remote controls etc. which use some form of energy to transfer information without the use of wires. Information is transferred in this manner over both short and long distances.

### Applications:-

**Mobile telephones:** - One of the best-known examples of wireless technology is the mobile phone, also known as a cellular phone, with more than 4.6 billion mobile cellular subscriptions worldwide as of the end of 2010. These wireless phones use radio waves to enable their users to make phone calls from many locations worldwide. They can be used within range of the mobile telephone site used to house the equipment required to transmit and receive the radio signals from these instruments

**Wireless data communications:** - Wireless data communications are an essential component of mobile computing. The various available technologies differ in local availability, coverage range and performance, and in some circumstances, users must be able to employ multiple connection types and switch between them. To simplify the experience for the user, connection manager software can be used, or a mobile VPN deployed to handle the multiple connections as a secure, single virtual network. Supporting technologies include:

**Wi-Fi** is a wireless local area network that enables portable computing devices to connect easily to the Internet., Wi-Fi approaches speeds of some types of wired Ethernet. Wi-Fi has become the de facto standard for access in private homes, within offices, and at public hotspots. Some businesses charge customers a monthly fee for service, while others have begun offering it for free in an effort to increase the sales of their goods.

**Cellular data service** offers coverage within a range of 10-15 miles from the nearest cell site. Speeds have increased as technologies have evolved, from earlier technologies such as GSM, CDMA and GPRS, to 3G networks such as W-CDMA, EDGE or CDMA2000.

**Mobile Satellite Communications** may be used where other wireless connections are unavailable, such as in largely rural areas or remote locations Satellite communications are especially important for transportation, aviation, maritime and military use.

**Wireless energy transfer:** - Wireless energy transfer is a process whereby electrical energy is transmitted from a power source to an electrical load that does not have a built-in power source, without the use of interconnecting wires.

Computer interface devices:- Answering the call of customers frustrated with cord clutter, many manufacturers of computer peripherals turned to wireless technology to satisfy their consumer base .Originally these units used bulky, highly limited transceivers to mediate between a computer and a keyboard and mouse; however, more recent generations have used small, high-quality devices, some even incorporating Bluetooth. These systems have become so ubiquitous that some users have begun

complaining about a lack of wired peripherals. Wireless devices tend to have a slightly slower response time than their wired counterparts; however, the gap is decreasing

### **Short History of Wireless Communications:-**

The world's first wireless telephone conversation occurred in 1880, when Alexander Graham Bell and Charles Sumner Tainter invented and patented the photo phone, a telephone that conducted audio conversations wirelessly over modulated light beams (which are narrow projections of electromagnetic waves). In that distant era, when utilities did not yet exist to provide electricity and lasers had not even been imagined in science fiction, there were no practical applications for their invention, which was highly limited by the availability of both sunlight and good weather. Similar to free-space optical communication, the photo phone also required a clear line of sight between its transmitter and its receiver. It would be several decades before the photo phone's principles found their first practical applications in military communications and later in fiber-optic communications.

**Market of Mobile Communications:** - Mobile marketing is marketing on or with a mobile device, such as a cell phone. Mobile marketing can also be defined as “the use of the mobile medium as a means of marketing communication”, the “distribution of any kind of promotional or advertising messages to customer through wireless networks”. More specific definition is the following: “using interactive wireless media to provide customers with time and location sensitive, personalized information that promotes goods, services and ideas, thereby generating value for all stakeholders”.

Mobile marketing is commonly known as wireless marketing, although viewing advertising on a computer connected to a home local area network is not considered to be mobile marketing.

### **SMS marketing**

Marketing through cell phones' SMS (Short Message Service) became increasingly popular in the early 2000s in Europe and some parts of Asia when businesses started to collect mobile phone numbers and send off wanted (or unwanted) content. On average, SMS messages are read within four minutes, making them highly convertible.

### **MMS**

MMS mobile marketing can contain a timed slideshow of images, text, audio and video. This mobile content is delivered via MMS (Multimedia Message Service). Nearly all new phones produced with a color screen are capable of sending and receiving standard MMS message. Brands are able to both send (mobile terminated) and receive (mobile originated) rich content through MMS A2P (application-to-person) mobile networks to mobile subscribers. In some networks, brands are also able to sponsor messages that are sent P2P (person-to-person).

### **Push notifications**

Push Notifications were first introduced to smart phones by Apple with the advent of the iPhone in 2007. They were later further popularized with the Android operational system, where the notifications are shown on the top of the screen. It has helped application owners to communicate directly with their end users in a simple and effective way. If not used wisely it can quickly alienate users as it causes interruptions to their current activities on the phone. It can be much cheaper if compared to SMS Marketing for the long run, but it can become quite expensive on the short run, because the cost involved

in application development. Once the application is downloading and installed provided the feature is not turned off it is practically free, because it uses internet bandwidth only. SMS and Push Notifications can be part of a well developed Inbound Mobile Marketing Strategy.

### **In-game mobile marketing**

There are essentially four major trends in mobile gaming right now: interactive real-time 3D games, massive multi-player games and social networking games. This means a trend towards more complex and more sophisticated, richer game play. On the other side, there are the so-called casual games, i.e. games that are very simple and very easy to play. Most mobile games today are such casual games and this will probably stay so for quite a while to come.

### **Elementary Knowledge on Wireless Transmission:-**

**Frequency of Radio Transmission:-** Radio frequency (RF) is a rate of oscillation in the range of about 3 kHz to 300 GHz, which corresponds to the frequency of radio waves, and the alternating currents which carry radio signals. RF usually refers to electrical rather than mechanical oscillations; however, mechanical RF systems do exist (see mechanical filter and RF MEMS).

Although radio *frequency* is a rate of oscillation, the term "radio frequency" or its abbreviation "RF" are also used as a synonym for radio – i.e. to describe the use of wireless communication, as opposed to communication via electric wires.

**SIGNAL:** - In telephony, a signal is special data that is used to set up or control communication.

In electronics, a signal is an electric current or electromagnetic field used to convey data from one place to another. The simplest form of signal is a direct current (DC) that is switched on and off; this is the principle by which the early telegraph worked. More complex signals consist of an alternating-current (AC) or electromagnetic carrier that contains one or more data streams.

**Antennas:** - Antenna (radio), also known as an aerial, a transducer designed to transmit or receive electromagnetic (e.g. TV or radio) waves

Television antenna (or TV aerial), is an antenna specifically designed for the reception of broadcast television signals

### **Signal Propagation:-**

Radio propagation is the behavior of radio waves when they are transmitted, or propagated from one point on the Earth to another, or into various parts of the atmosphere. As a form of electromagnetic radiation, like light waves, radio waves are affected by the phenomena of reflection, refraction, diffraction, absorption, polarization and scattering.

Radio propagation is affected by the daily changes of water vapor in the troposphere and ionization in the upper atmosphere, due to the Sun. Understanding the effects of varying conditions on radio propagation has many practical applications, from choosing frequencies for international shortwave broadcasters, to designing reliable mobile telephone systems, to radio navigation, to operation of radar systems.

**Path Loss of Radio Signals:** - The signal path loss is essentially the reduction in power density of an electromagnetic wave or signal as it propagates through the environment in which it is travelling.

There are many reasons for the radio path loss that may occur:-

- **Free space loss:** The free space loss occurs as the signal travels through space without any other effects attenuating the signal it will still diminish as it spreads out. This can be thought of as the radio communications signal spreading out as an ever increasing sphere. As the signal has to cover a wider area, conservation of energy tells us that the energy in any given area will reduce as the area covered becomes larger.
- **Absorption losses:** Absorption losses occur if the radio signal passes into a medium which is not totally transparent to radio signals. This can be likened to a light signal passing through transparent glass.
- **Diffraction:** Diffraction losses occur when an object appears in the path. The signal can diffract around the object, but losses occur. The loss is higher the more rounded the object. Radio signals tend to diffract better around sharp edges.
- **Multipath:** In a real terrestrial environment, signals will be reflected and they will reach the receiver via a number of different paths. These signals may add or subtract from each other depending upon the relative phases of the signals. If the receiver is moved the scenario will change and the overall received signal will be found vary with position. Mobile receivers (e.g. cellular telecommunications phones) will be subject to this effect which is known as Rayleigh fading.
- **Terrain:** The terrain over which signals travel will have a significant effect on the signal. Obviously hills which obstruct the path will considerably attenuate the signal, often making reception impossible. Additionally at low frequencies the composition of the earth will have a marked effect. For example on the Long Wave band, it is found that signals travel best over more conductive terrain, e.g. sea paths or over areas that are marshy or damp. Dry sandy terrain gives higher levels of attenuation.
- **Buildings and vegetation:** For mobile applications, buildings and other obstructions including vegetation have a marked effect. Not only will buildings reflect radio signals, they will also absorb them. Cellular communications are often significantly impaired within buildings. Trees and foliage can attenuate radio signals, particularly when wet.
- **Atmosphere:** The atmosphere can affect radio signal paths. At lower frequencies, especially below 30 - 50MHz, the ionosphere has a significant effect; reflecting (or more correctly refracting) them back to Earth. At frequencies above 50 MHz and more the troposphere has a major effect, refracting the signals back to earth as a result of changing refractive index. For UHF broadcast this can extend coverage to approximately a third beyond the horizon.

These reasons represent some of the major elements causing signal path loss for any radio system.

**Propagation Effects:** - Radio propagation is affected by the daily changes of water vapor in the troposphere and ionization in the upper atmosphere, due to the Sun. Understanding the effects of varying conditions on radio propagation has many practical applications, from choosing frequencies for



international shortwave broadcasters, to designing reliable mobile telephone systems, to radio navigation, to operation of radar systems.

Radio propagation is also affected by several other factors determined by its path from point to point. This path can be a direct line of sight path or an over-the-horizon path aided by refraction in the ionosphere, which is a region between approximately 60 and 600 km. Factors influencing ionospheric radio signal propagation can include sporadic-E, spread-F, solar flares, geomagnetic storms, ionospheric layer tilts, and solar proton events.

Radio waves at different frequencies propagate in different ways. At extra low frequencies (ELF) and very low frequencies the wavelength is very much larger than the separation between the earth's surface and the D layer of the ionosphere, so electromagnetic waves may propagate in this region as a waveguide. Indeed, for frequencies below 20 kHz, the wave propagates as a single waveguide mode with a horizontal magnetic field and vertical electric field. The interaction of radio waves with the ionized regions of the atmosphere makes radio propagation more complex to predict and analyze than in free space. Ionospheric radio propagation has a strong connection to space weather. A sudden ionospheric disturbance or shortwave fadeout is observed when the x-rays associated with a solar flare ionize the ionospheric D-region. Enhanced ionization in that region increases the absorption of radio signals passing through it. During the strongest solar x-ray flares, complete absorption of virtually all ionosphericly propagated radio signals in the sunlit hemisphere can occur. These solar flares can disrupt HF radio propagation and affect GPS accuracy.

**Multiplexing:** - In telecommunications and computer networks, **multiplexing** (also known as **muxing**) is a method by which multiple analogue message signals or digital data streams are combined into one signal over a shared medium. The aim is to share an expensive resource. For example, in telecommunications, several telephone calls may be carried using one wire. Multiplexing originated in telegraphy in the 1870s, and is now widely applied in communications. In telephony, George Owen Squier is credited with the development of telephone carrier multiplexing in 1910.

**Space Division Multiplexing:** - Space-division multiple access (SDMA) is a channel access method based on creating parallel spatial pipes next to higher capacity pipes through spatial multiplexing and/or diversity, by which it is able to offer superior performance in radio multiple access communication systems. In traditional mobile cellular network systems, the base station has no information on the position of the mobile units within the cell and radiates the signal in all directions within the cell in order to provide radio coverage. This results in wasting power on transmissions when there are no mobile units to reach, in addition to causing interference for adjacent cells using the same frequency, so called co-channel cells. Likewise, in reception, the antenna receives signals coming from all directions including noise and interference signals. By using smart antenna technology and differing spatial locations of mobile units within the cell, space-division multiple access techniques offer attractive performance enhancements. The radiation pattern of the base station, both in transmission and reception is adapted to each user to obtain highest gain in the direction of that user. This is often done using phased array techniques.

In GSM cellular networks, the base station is aware of the distance (but not direction) of a mobile phone by use of a technique called "timing advance" (TA). The base transceiver station (BTS) can determine

how distant the mobile station (MS) is by interpreting the reported TA. This information, along with other parameters, can then be used to power down the BTS or MS, if a power control feature is implemented in the network. The power control in either BTS or MS is implemented in most modern networks, especially on the MS, as this ensures a better battery life for the MS. This is also why having a BTS close to the user results in less exposure to electromagnetic radiation.

This is why one may actually be safer to have a BTS close to them as their MS will be powered down as much as possible. For example, there is more power being transmitted from the MS than what one would receive from the BTS even if they were 6 meters away from a BTS mast. However, this estimation might not consider all the Mobile stations that a particular BTS is supporting with EM radiation at any given time.

In the same manner, 5th generation mobile networks will be focused in utilizing the given position of the MS in relation to BTS in order to focus all MS Radio frequency power to the BTS direction and vice versa, thus enabling power savings for the Mobile Operator, reducing MS SAR index, reducing the EM field around base stations since beam forming will concentrate power when it will be actually used rather than spread uniformly around the BTS, reducing health and safety concerns, enhancing spectral efficiency, and decreased MS battery consumption.<sup>1</sup>

**Frequency Division Multiplexing** :- In telecommunications, frequency-division multiplexing (FDM) is a technique by which the total bandwidth available in a communication medium is divided into a series of non-overlapping frequency sub-bands, each of which is used to carry a separate signal. This allows a single transmission medium such as the radio spectrum, a cable or optical fiber to be shared by many signals.

The most natural example of frequency-division multiplexing is radio and television broadcasting, in which multiple radio signals at different frequencies pass through the air at the same time. Another example is cable television, in which many television channels are carried simultaneously on a single cable. FDM is also used by telephone systems to transmit multiple telephone calls through high capacity trunk lines, communications satellites to transmit multiple channels of data on uplink and downlink radio beams, and broadband DSL modems to transmit large amounts of computer data through twisted pair telephone lines, among many other uses.

An analogous technique called wavelength division multiplexing is used in fiber optic communication, in which multiple channels of data are transmitted over a single optical fiber using different wavelengths (frequencies) of light.

**Time Division Multiplexing**: - Time-division multiplexing (TDM) is a method of transmitting and receiving independent signals over a common signal path by means of synchronized switches at the each end of the transmission line so that each signal appears on the line only a fraction of time in an alternating pattern. This form of signal multiplexing was developed in telecommunications for telegraphy systems in the late 1800s, but found its most common application in digital telephony in the second half of the 20th century. Time-division multiplexing is used primarily for digital signals, but may be applied in analog



multiplexing in which two or more signals or bit streams are transferred appearing simultaneously as sub-channels in one communication channel, but are physically taking turns on the channel. The time domain is divided into several recurrent *time slots* of fixed length, one for each sub-channel. A sample byte or data block of sub-channel 1 is transmitted during time slot 1, sub-channel 2 during time slot 2, etc. One TDM frame consists of one time slot per sub-channel plus a synchronization channel and sometimes error correction channel before the synchronization. After the last sub-channel, error correction, and synchronization, the cycle starts all over again with a new frame, starting with the second sample, byte or data block from sub-channel 1

**Code Division Multiplexing:** - Code division multiple access (CDMA) is a channel access method used by various radio communication technologies.

CDMA is an example of multiple access, which is where several transmitters can send information simultaneously over a single communication channel. This allows several users to share a band of frequencies (see bandwidth). To permit this to be achieved without undue interference between the users CDMA employs spread-spectrum technology and a special coding scheme (where each transmitter is assigned a code).

CDMA is used as the access method in many mobile phone standards such as cdmaOne, CDMA2000 (the 3G evolution of cdmaOne), and WCDMA (the 3G standard used by GSM carriers), which are often referred to as simply *CDMA*.

**modulation** :- In electronics and telecommunications, **modulation** is the process of varying one or more properties of a periodic waveform, called the *carrier signal*, with a *modulating signal* which typically contains information to be transmitted. This is done in a similar fashion to a musician modulating a tone (a periodic waveform) from a musical instrument by varying its volume, timing and pitch. The three key parameters of a periodic waveform are its amplitude ("volume"), its phase ("timing") and its frequency ("pitch"). Any of these properties can be modified in accordance with a low frequency signal to obtain the modulated signal. Typically a high-frequency sinusoid waveform is used as carrier signal, but a square wave pulse train may also be used.

In telecommunications, modulation is the process of conveying a message signal, for example a digital bit stream or an analog audio signal, inside another signal that can be physically transmitted. Modulation of a sine waveform is used to transform a baseband message signal into a pass band signal, for example low-frequency audio signal into a radio-frequency signal (RF signal). In radio communications, cable TV systems or the public switched telephone network for instance, electrical signals can only be transferred over a limited pass band frequency spectrum, with specific (non-zero) lower and upper cutoff frequencies. Modulating a sine-wave carrier makes it possible to keep the frequency content of the transferred signal as close as possible to the centre frequency (typically the carrier frequency) of the pass band.

A device that performs modulation is known as a modulator and a device that performs the inverse operation of modulation is known as a demodulator (sometimes *detector* or *demod*). A device that can do both operations is a modem (from "**modulator**–**demodulator**").

The aim of **digital modulation** is to transfer a digital bit stream over an analog band pass channel, for example over the public switched telephone network (where a band pass filter limits the frequency range to between 300 and 3400 Hz), or over a limited radio frequency band.

The aim of **analog modulation** is to transfer an analog baseband (or low pass) signal, for example an audio signal or TV signal, over an analog band pass channel at a different frequency, for example over a limited radio frequency band or a cable TV network channel.

Analog and digital modulation facilitate frequency division multiplexing (FDM), where several low pass information signals are transferred simultaneously over the same shared physical medium, using separate pass band channels (several different carrier frequencies).

**Amplitude-shift keying** :- **Amplitude-shift keying (ASK)** is a form of amplitude modulation that represents digital data as variations in the amplitude of a carrier wave.

Any digital modulation scheme uses a finite number of distinct signals to represent digital data. ASK uses a finite number of amplitudes, each assigned a unique pattern of binary digits. Usually, each amplitude encodes an equal number of bits. Each pattern of bits forms the symbol that is represented by the particular amplitude. The demodulator, which is designed specifically for the symbol-set used by the modulator, determines the amplitude of the received signal and maps it back to the symbol it represents, thus recovering the original data. Frequency and phase of the carrier are kept constant.

Like AM, ASK is also linear and sensitive to atmospheric noise, distortions, propagation conditions on different routes in PSTN, etc. Both ASK modulation and demodulation processes are relatively inexpensive. The ASK technique is also commonly used to transmit digital data over optical fiber. For LED transmitters, binary 1 is represented by a short pulse of light and binary 0 by the absence of light. Laser transmitters normally have a fixed "bias" current that causes the device to emit a low light level. This low level represents binary 0, while a higher-amplitude lightwave represents binary 1.

The simplest and most common form of ASK operates as a switch, using the presence of a carrier wave to indicate a binary one and its absence to indicate a binary zero. This type of modulation is called on-off keying, and is used at radio frequencies to transmit Morse code (referred to as continuous wave operation),

More sophisticated encoding schemes have been developed which represent data in groups using additional amplitude levels. For instance, a four-level encoding scheme can represent two bits with each shift in amplitude; an eight-level scheme can represent three bits; and so on. These forms of amplitude-shift keying require a high signal-to-noise ratio for their recovery, as by their nature much of the signal is transmitted at reduced power.

**Frequency-shift keying (FSK)** is a frequency modulation scheme in which digital information is transmitted through discrete frequency changes of a carrier wave.

The simplest FSK is **binary FSK (BFSK)**. BFSK uses a pair of discrete frequencies to transmit binary (0s and 1s) information. With this scheme, the "1" is called the mark frequency and the "0" is called the space frequency. The time domain of an FSK modulated carrier is illustrated in the figures to the right.

**Phase Shift Keying**:- **Phase-shift keying (PSK)** is a digital modulation scheme that conveys data by changing, or modulating, the phase of a reference signal (the carrier wave).

Any digital modulation scheme uses a finite number of distinct signals to represent digital data. PSK uses a finite number of phases; each assigned a unique pattern of binary digits. Usually, each phase encodes an equal number of bits. Each pattern of bits forms the symbol that is represented by the particular phase. The demodulator, which is designed specifically for the symbol-set used by the modulator, determines the phase of the received signal and maps it back to the symbol it represents, thus recovering the original data. This requires the receiver to be able to compare the phase of the received signal to a reference signal — such a system is termed coherent (and referred to as CPSK).

Alternatively, instead of operating with respect to a constant reference wave, the broadcast can operate with respect to itself. Changes in phase of a single broadcast waveform can be considered the significant items. In this system, the demodulator determines the changes in the phase of the received signal rather than the phase (relative to a reference wave) itself. Since this scheme depends on the difference between successive phases, it is termed **differential phase-shift keying (DPSK)**. DPSK can be significantly simpler to implement than ordinary PSK since there is no need for the demodulator to have a copy of the reference signal to determine the exact phase of the received signal (it is a non-coherent scheme). In exchange, it produces more erroneous demodulation.

**Multi-carrier modulation (MCM)** is a method of transmitting data by splitting it into several components, and sending each of these components over separate carrier signals. The individual carriers have narrow bandwidth, but the composite signal can have broad bandwidth.

**The advantages of MCM** include relative immunity to fading caused by transmission over more than one path at a time (multipath fading), less susceptibility than single-carrier systems to interference caused by impulse noise, and enhanced immunity to inter-symbol interference. Limitations include difficulty in synchronizing the carriers under marginal conditions, and a relatively strict requirement that amplification be linear.

MCM was first used in analog military communications in the 1950s. Recently, MCM has attracted attention as a means of enhancing the bandwidth of digital communications over media with physical limitations. The scheme is used in some audio broadcast services. The technology lends itself to digital television, and is used as a method of obtaining high data speeds in asymmetric digital subscriber line (ADSL) systems. MCM is also used in wireless local area networks (WLANs).

Also see orthogonal frequency-division multiplexing (OFDM), frequency-division multiplexing (FDM), and time-division multiplexing (TDM).

In telecommunication and radio communication, **spread-spectrum** techniques are methods by which a signal (e.g. an electrical, electromagnetic, or acoustic signal) generated with a particular bandwidth is deliberately spread in the frequency domain, resulting in a signal with a wider bandwidth. These techniques are used for a variety of reasons, including the establishment of secure communications, increasing resistance to natural interference, noise and jamming, to prevent detection, and to limit power flux density (e.g. in satellite downlinks).

## Spread-spectrum telecommunications:-

This is a technique in which a (telecommunication) signal is transmitted on a bandwidth considerably larger than the frequency content of the original information. Frequency hopping is a basic modulation technique used in spread spectrum signal transmission.

**Spread-spectrum** telecommunications is a signal structuring technique that employs direct sequence, frequency hopping, or a hybrid of these, which can be used for multiple access and/or multiple functions. This technique decreases the potential interference to other receivers while achieving privacy. Spread spectrum generally makes use of a sequential noise-like signal structure to spread the normally narrowband information signal over a relatively wideband (radio) band of frequencies. The receiver correlates the received signals to retrieve the original information signal. Originally there were two motivations: either to resist enemy efforts to jam the communications (anti-jam, or AJ), or to hide the fact that communication was even taking place, sometimes called low probability of intercept (LPI).

**Frequency-hopping spread spectrum (FHSS)**, direct-sequence spread spectrum (DSSS), time-hopping spread spectrum (THSS), chirp spread spectrum (CSS), and combinations of these techniques are forms of spread spectrum. Each of these techniques employs pseudorandom number sequences created using pseudorandom number generators to determine *and* control the spreading pattern of the signal across the allocated bandwidth. Ultra-wideband (UWB) is another modulation technique that accomplishes the same purpose, based on transmitting short duration pulses.

In communications, **direct-sequence spread spectrum (DSSS)** is a modulation technique. As with other spread spectrum technologies, the transmitted signal takes up more bandwidth than the information signal that modulates the carrier or broadcast frequency. The name 'spread spectrum' comes from the fact that the carrier signals occur over the full bandwidth (spectrum) of a device's transmitting frequency.

DSSS phase-modulates a sine wave pseudo randomly with a continuous string of pseudo noise (PN) code symbols called "chips", each of which has a much shorter duration than an information bit. That is, each information bit is modulated by a sequence of much faster chips. Therefore, the chip rate is much higher than the information signal bit rate.

1. DSSS uses a signal structure in which the sequence of chips produced by the transmitter is already known by the receiver. The receiver can then use the same *PN sequence* to counteract the effect of the PN sequence on the received signal in order to reconstruct the information signal.

**Frequency-hopping spread spectrum (FHSS)** is a method of transmitting radio signals by rapidly switching a carrier among many frequency channels, using a pseudorandom sequence known to both transmitter and receiver. It is utilized as a multiple access method in the **frequency-hopping code division multiple access (FH-CDMA)** scheme.

## Spread-spectrum

A spread-spectrum transmission offers three main advantages over a fixed-frequency transmission:

1. Spread-spectrum signals are highly resistant to narrowband interference. The process of re-collecting a spread signal spreads out the interfering signal, causing it to recede into the background.
2. Spread-spectrum signals are difficult to intercept. A spread-spectrum signal may simply appear as an increase in the background noise to a narrowband receiver. An eavesdropper may have difficulty intercepting a transmission in real time if the pseudorandom sequence is not known.
3. Spread-spectrum transmissions can share a frequency band with many types of conventional transmissions with minimal interference. The spread-spectrum signals add minimal noise to the narrow-frequency communications, and vice versa. As a result, bandwidth can be utilized more efficiently.

### **Military use:-**

Spread-spectrum signals are highly resistant to deliberate jamming, unless the adversary has knowledge of the spreading characteristics. Military radios use cryptographic techniques to generate the channel sequence under the control of a secret Transmission Security Key (TRANSEC) that the sender and receiver share in advance.

By itself, frequency hopping provides only limited protection against eavesdropping and jamming. There is a simple algorithm that effectively discovers the sequence of frequencies. To get around this weakness most modern military frequency hopping radios employ separate encryption devices such as the KY-57. U.S. military radios that use frequency hopping include the JTIDS/MIDS family, HAVE QUICK and SINCGARS.

### **Cellular Systems:-**

The covering area of an operator is divided into cells. A cell corresponds to the covering area of one transmitter or a small collection of transmitters. The size of a cell is determined by the transmitter's power.

The concept of cellular systems is the use of low power transmitters in order to enable the efficient reuse of the frequencies. In fact, if the transmitters used are very powerful, the frequencies cannot be reused for hundreds of kilometers as they are limited to the covering area of the transmitter.

The frequency band allocated to a cellular mobile radio system is distributed over a group of cells and this distribution is **repeated** in all the domain of an operator. The whole number of radio channels available can then be used in each group of cells that form the covering area of an operator. Frequencies used in a cell are reused several cells away. The distance between the cells using the same frequency must be sufficient to avoid interference. The *frequency reuse* will increase considerably the capacity in number of users.

In order to work properly, a cellular system must verify the following two main conditions:

- The power level of a transmitter within a single cell **must be limited** in order to reduce the interference with the transmitters of neighboring cells. The interference will not produce any damage to the system if a distance of about *2.5-3 times the diameter of a cell* is reserved between transmitters. This also depends on the performance of the receiver's filters.

- Neighboring cells **can not share** the same channels. To reduce the interference, the frequencies must be reused only within a certain **pattern**.

## UNIT-II

### Elementary Knowledge on Medium Access Control:-

In the seven-layer OSI model of computer networking, media access control (MAC) data communication protocol is a sub layer of the data link layer, which itself is layer 2. The MAC sub layer provides addressing and channel access control mechanisms that make it possible for several terminals or network nodes to communicate within a multiple access network that incorporates a shared medium, e.g. Ethernet. The hardware that implements the MAC is referred to as a *medium access controller*.

The MAC sub layer acts as an interface between the logical link control (LLC) sub layer and the network's physical layer. The MAC layer emulates a full-duplex logical communication channel in a multi-point network. This channel may provide unicast, multicast or broadcast communication service.

### Motivation for a specialized (MAC):-

The **Media Access Control (MAC)** data communication protocol sub-layer, also known as the Medium Access Control, is a sub layer of the Data Link Layer specified in the seven-layer OSI model (layer 2). The hardware that implements the MAC is referred to as a **Medium Access Controller**. The MAC sub-layer acts as an interface between the Logical Link Control (LLC) sub layer and the network's physical layer. The MAC layer emulates a full-duplex logical communication channel in a multi-point network. This channel may provide uni cast, multicast or broadcast communication service.





तेजस्वि नावधीतमस्तु  
ISO 9001:2008 & 14001:2004

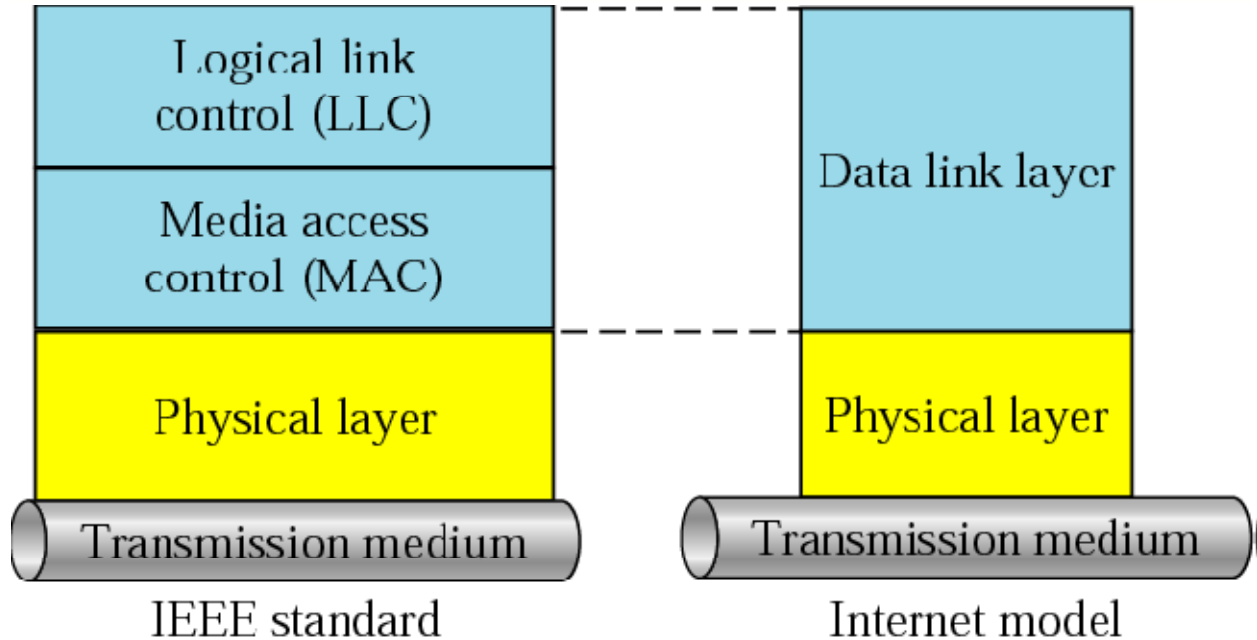

### LLC and MAC sub layers

#### Motivation for a specialized MAC

One of the most commonly used MAC schemes for wired networks is carrier sense multiple access with collision detection (CSMA/CD). In this scheme, a sender senses the medium (a wire or coaxial cable) to see if it is free. If the medium is busy, the sender waits until it is free. If the medium is free, the sender starts transmitting data and continues to listen into the medium. If the sender detects a collision while sending, it stops at once and sends a jamming signal. But this scheme does not work well with wireless networks. The problems are:

- Signal strength decreases proportional to the square of the distance
- The sender would apply CS and CD, but the collisions happen at the receiver
- It might be a case that a sender cannot “hear” the collision, i.e., CD does not work
- Furthermore, CS might not work, if for e.g., a terminal is “hidden”

#### Hidden and Exposed Terminals

Consider the scenario with three mobile phones as shown below. The transmission range of A reaches B, but not C (the detection range does not reach C either). The transmission range of C reaches B, but not A. Finally, the transmission range of B reaches A and C, i.e., A cannot detect C and vice versa.

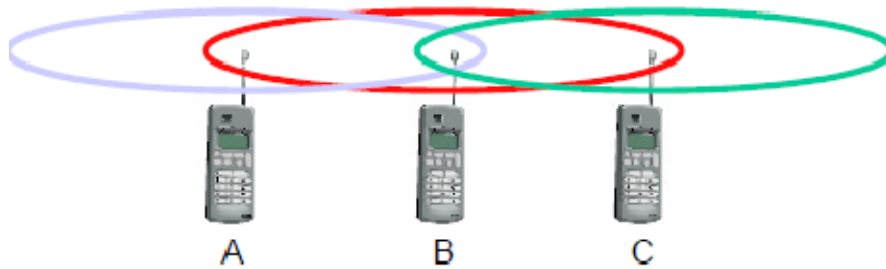

### Hidden terminals

- A sends to B, C cannot hear A
- C wants to send to B, C senses a “free” medium (CS fails) and starts transmitting
- Collision at B occurs, A cannot detect this collision (CD fails) and continues with its transmission to B
- A is “hidden” from C and vice versa

### Exposed terminals

- B sends to A, C wants to send to another terminal (not A or B) outside the range
- C senses the carrier and detects that the carrier is busy.
- C postpones its transmission until it detects the medium as being idle again
- but A is outside radio range of C, waiting is **not** necessary
- C is “exposed” to B

Hidden terminals cause collisions, whereas Exposed terminals causes unnecessary delay.

### Near and far terminals

Consider the situation shown below. A and B are both sending with the same transmission power.

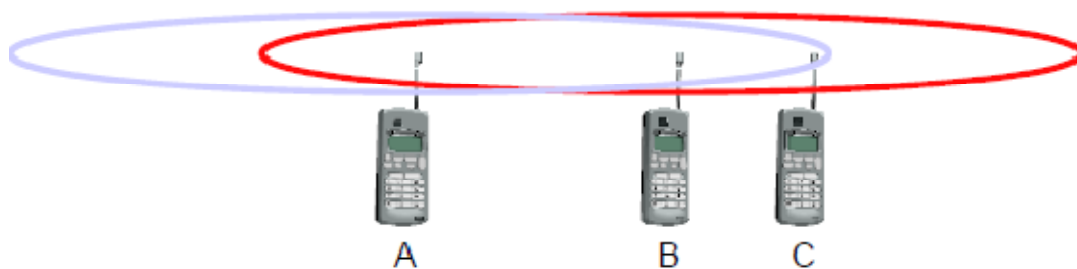

- Signal strength decreases proportional to the square of the distance
- So, B’s signal drowns out A’s signal making C unable to receive A’s transmission

- If C is an arbiter for sending rights, B drown out A's signal on the physical layer making C unable to hear out A.

The **near/far effect** is a severe problem of wireless networks using CDM. All signals should arrive at the receiver with more or less the same strength for which Precise power control is to be implemented.

### SDMA

**Space Division Multiple Access (SDMA)** is used for allocating a separated space to users in wireless networks. A typical application involves assigning an optimal base station to a mobile phone user. The mobile phone may receive several base stations with different quality. A MAC algorithm could now decide which base station is best, taking into account which frequencies (FDM), time slots (TDM) or code (CDM) are still available. The basis for the SDMA algorithm is formed by cells and sectorized antennas which constitute the infrastructure implementing **space division multiplexing (SDM)**. SDM has the unique advantage of not requiring any multiplexing equipment. It is usually combined with other multiplexing techniques to better utilize the individual physical channels.

### FDMA

Frequency division multiplexing (FDM) describes schemes to subdivide the frequency dimension into several non-overlapping frequency bands.

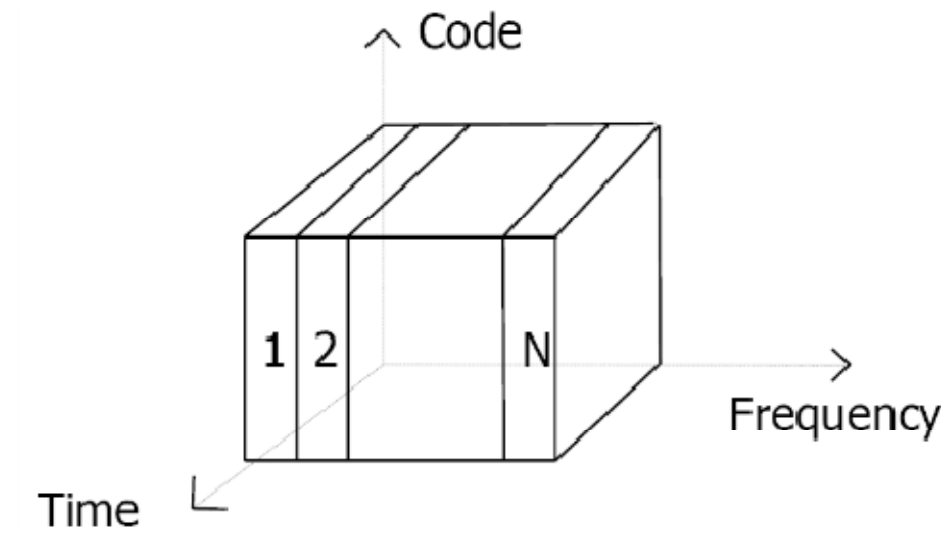

Frequency Division Multiple Access is a method employed to permit several users to transmit simultaneously on one satellite transponder by assigning a specific frequency within the channel to each user. Each conversation gets its own, unique, radio channel. The channels are relatively narrow, usually 30 KHz or less and are defined as either transmit or receive channels. A full duplex conversation requires

a transmit & receive channel pair. FDM is often used for simultaneous access to the medium by base station and mobile station in cellular networks establishing a duplex channel. A scheme called **frequency division duplexing (FDD)** in which the two directions, mobile station to base station and vice versa are now separated using different frequencies.

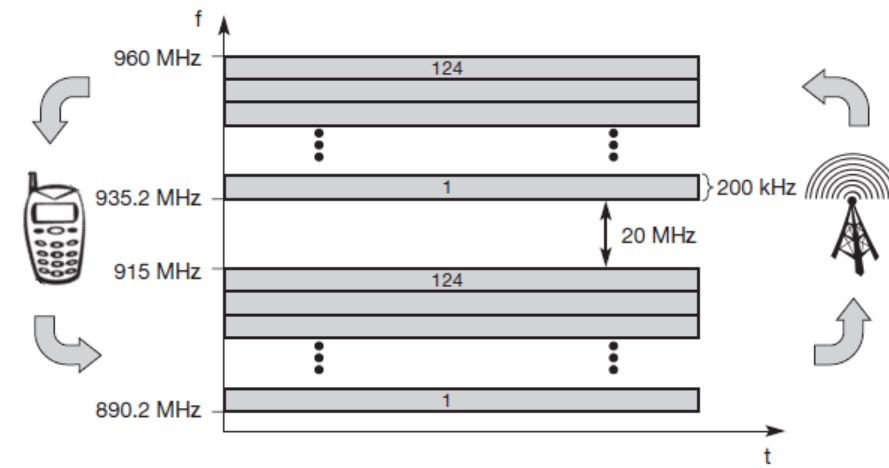

### **FDM for multiple access and duplex**

The two frequencies are also known as **uplink**, i.e., from mobile station to base station or from ground control to satellite, and as **downlink**, i.e., from base station to mobile station or from satellite to ground control. The basic frequency allocation scheme for GSM is fixed and regulated by national authorities. All uplinks use the band between 890.2 and 915 MHz, all downlinks use 935.2 to 960 MHz. According to FDMA, the base station, shown on the right side, allocates a certain frequency for up- and downlink to establish a duplex channel with a mobile phone. Up- and downlink have a fixed relation. If the uplink frequency is  $f_u = 890 \text{ MHz} + n \cdot 0.2 \text{ MHz}$ , the downlink frequency is  $f_d = f_u + 45 \text{ MHz}$ , i.e.,  **$f_d = 935 \text{ MHz} + n \cdot 0.2 \text{ MHz}$**  for a certain channel  $n$ . The base station selects the channel. Each channel (uplink and downlink) has a bandwidth of 200 kHz.

This scheme also has disadvantages. While radio stations broadcast 24 hours a day, mobile communication typically takes place for only a few minutes at a time. Assigning a separate frequency for each possible communication scenario would be a tremendous waste of (scarce) frequency resources. Additionally, the fixed assignment of a frequency to a sender makes the scheme very inflexible and limits the number of senders.

### **TDMA**

A more flexible multiplexing scheme for typical mobile communications is time division multiplexing (TDM). Compared to FDMA, time division multiple access (TDMA) offers a much more flexible

scheme, which comprises all technologies that allocate certain time slots for communication. Now synchronization between sender and receiver has to be achieved in the time domain. Again this can be done by using a fixed pattern similar to FDMA techniques, i.e., allocating a certain time slot for a channel, or by using a dynamic allocation scheme.

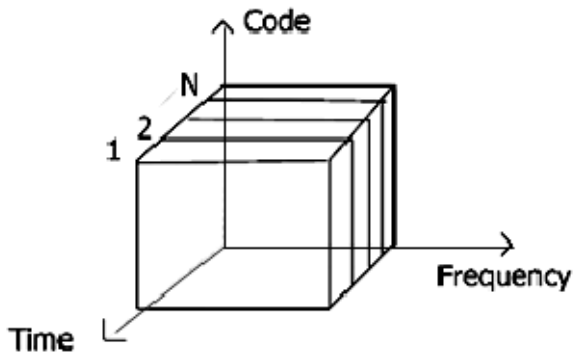

Listening to different frequencies at the same time is quite difficult, but listening to many channels separated in time at the same frequency is simple. Fixed schemes do not need identification, but are not as flexible considering varying bandwidth requirements.

**Fixed TDM**

The simplest algorithm for using TDM is allocating time slots for channels in a fixed pattern. This results in a fixed bandwidth and is the typical solution for wireless phone systems. MAC is quite simple, as the only crucial factor is accessing the reserved time slot at the right moment. If this synchronization is assured, each mobile station knows its turn and no interference will happen. The fixed pattern can be assigned by the base station, where competition between different mobile stations that want to access the medium is solved.

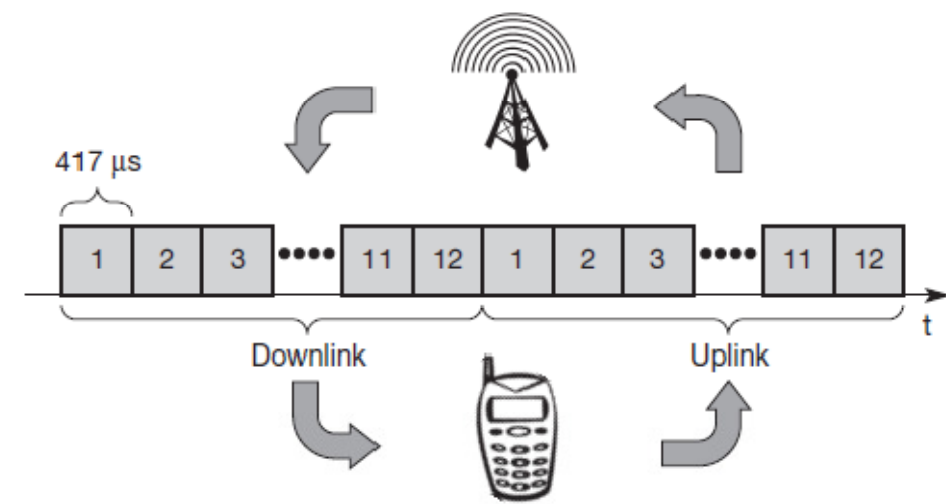

The above figure shows how these fixed TDM patterns are used to implement multiple access and a duplex channel between a base station and mobile station. Assigning different slots for uplink and downlink using the same frequency is called **time division duplex (TDD)**. As shown in the figure, the base station uses one out of 12 slots for the downlink, whereas the mobile station uses one out of 12 different slots for the uplink. Uplink and downlink are separated in time. Up to 12 different mobile stations can use the same frequency without interference using this scheme. Each connection is allotted its own up- and downlink pair. This general scheme still wastes a lot of bandwidth. It is too static, too inflexible for data communication. In this case, connectionless, demand-oriented TDMA schemes can be used

### Classical Aloha

In this scheme, TDM is applied without controlling medium access. Here each station can access the medium at any time as shown below:

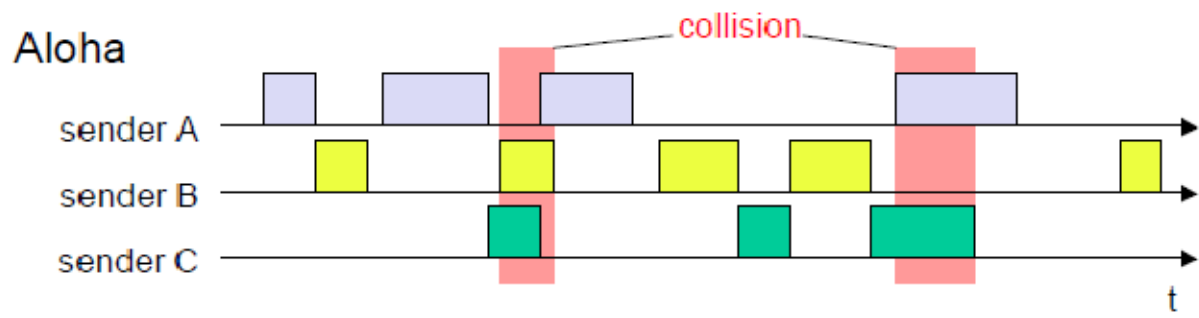

This is a random access scheme, without a central arbiter controlling access and without coordination among the stations. If two or more stations access the medium at the same time, a **collision** occurs and the transmitted data is destroyed. Resolving this problem is left to higher layers (e.g., retransmission of data). The simple Aloha works fine for a light load and does not require any complicated access mechanisms.

### **Slotted Aloha**

The first refinement of the classical Aloha scheme is provided by the introduction of time slots (**slotted Aloha**). In this case, all senders have to be **synchronized**, transmission can only start at the beginning of a **time slot** as shown below.



## Slotted Aloha

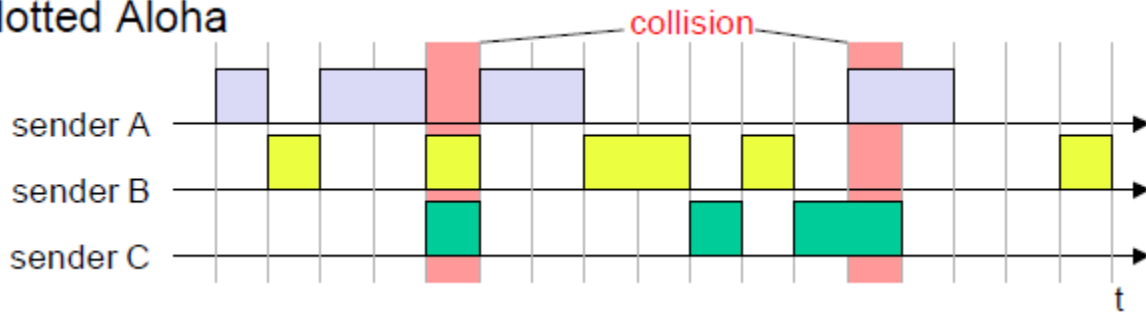

The introduction of slots raises the throughput from 18 per cent to 36 per cent, i.e., slotting doubles the throughput. Both basic Aloha principles occur in many systems that implement distributed access to a medium. Aloha systems work perfectly well under a light load, but they cannot give any hard transmission guarantees, such as maximum delay before accessing the medium or minimum throughput.

### Carrier sense multiple access

One improvement to the basic Aloha is sensing the carrier before accessing the medium. Sensing the carrier and accessing the medium only if the carrier is idle decreases the probability of a collision. But, as already mentioned in the introduction, hidden terminals cannot be detected, so, if a hidden terminal transmits at the same time as another sender, a collision might occur at the receiver. This basic scheme is still used in most wireless LANs. The different versions of CSMA are:

- **1-persistent CSMA:** Stations sense the channel and listens if its busy and transmit immediately, when the channel becomes idle. It's called 1-persistent CSMA because the host transmits with a probability of 1 whenever it finds the channel idle.
- **non-persistent CSMA:** stations sense the carrier and start sending immediately if the medium is idle. If the medium is busy, the station pauses a random amount of time before sensing the medium again and repeating this pattern.
- **p-persistent CSMA:** systems nodes also sense the medium, but only transmit with a probability of  $p$ , with the station deferring to the next slot with the probability  $1-p$ , i.e., access is slotted in addition

CSMA with collision avoidance (**CSMA/CA**) is one of the access schemes used in wireless LANs following the standard IEEE 802.11. Here sensing the carrier is combined with a back-off scheme in case of a busy medium to achieve some fairness among competing stations.

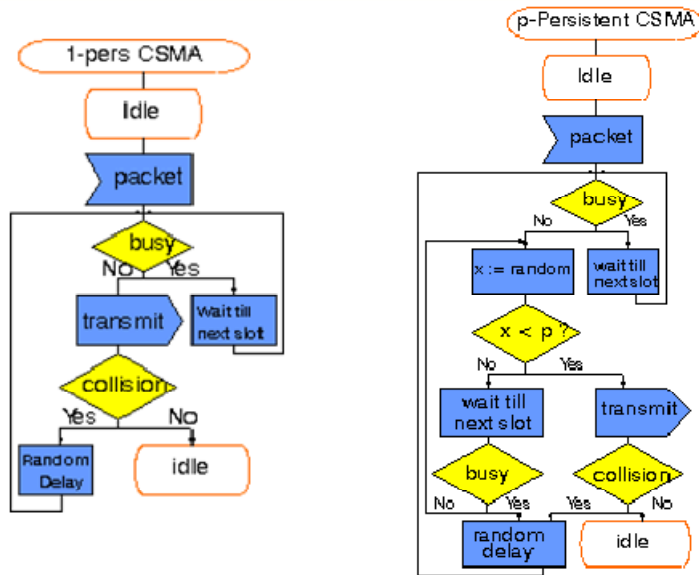

### Demand assigned multiple access

Channel efficiency for Aloha is 18% and for slotted Aloha is 36%. It can be increased to 80% by implementing reservation mechanisms and combinations with some (fixed) TDM patterns. These schemes typically have a reservation period followed by a transmission period. During the reservation period, stations can reserve future slots in the transmission period. While, depending on the scheme, collisions may occur during the reservation period, the transmission period can then be accessed without collision.

One basic scheme is **demand assigned multiple access (DAMA)** also called **reservation Aloha**, a scheme typical for satellite systems. It increases the amount of users in a pool of satellite channels that are available for use by any station in a network. It is assumed that not all users will need simultaneous access to the same communication channels. So that a call can be established, DAMA assigns a pair of available channels based on requests issued from a user. Once the call is completed, the channels are returned to the pool for an assignment to another call. Since the resources of the satellite are being used only in proportion to the occupied channels for the time in which they are being held, it is a perfect environment for voice traffic and data traffic in batch mode.

It has two modes as shown below.

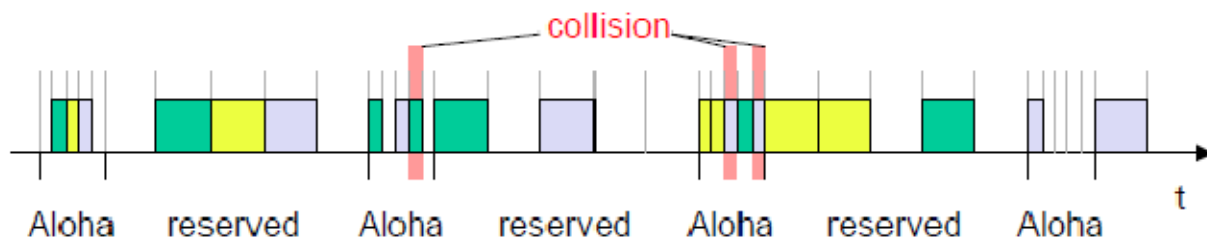

During a contention phase following the slotted Aloha scheme; all stations can try to reserve future slots. Collisions during the reservation phase do not destroy data transmission, but only the short requests for data transmission. If successful, a time slot in the future is reserved, and no other station is allowed to transmit during this slot. Therefore, the satellite collects all successful requests (the others are destroyed) and sends back a reservation list indicating access rights for future slots. All ground stations have to obey this list. To maintain the fixed TDM pattern of reservation and transmission, the stations have to be synchronized from time to time. DAMA is an **explicit reservation** scheme. Each transmission slot has to be reserved explicitly.

**PRMA packet reservation multiple access**

It is a kind of implicit reservation scheme where, slots can be reserved implicitly. A certain number of slots form a frame. The frame is repeated in time i.e., a fixed TDM pattern is applied. A base station, which could be a satellite, now broadcasts the status of each slot to all mobile stations. All stations receiving this vector will then know which slot is occupied and which slot is currently free.

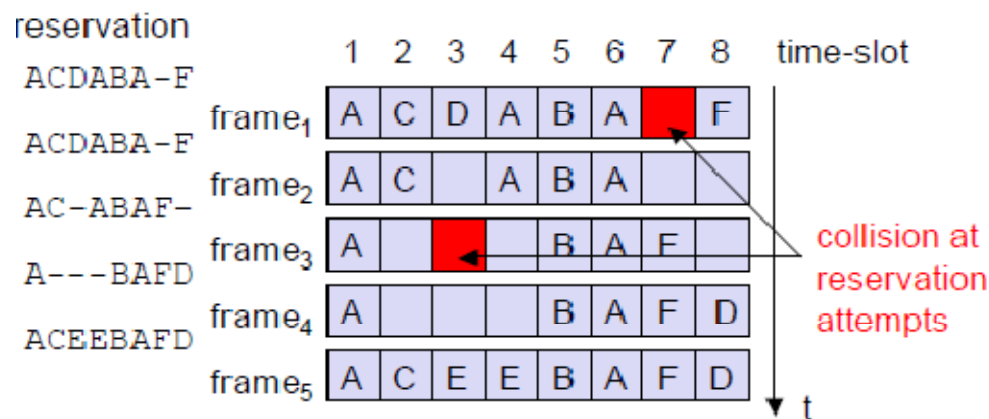

The base station broadcasts the reservation status 'ACDABA-F' to all stations, here A to F. This means that slots one to six and eight are occupied, but slot seven is free in the following transmission. All stations wishing to transmit can now compete for this free slot in Aloha fashion. The already occupied slots are not touched. In the example shown, more than one station wants to access this slot, so a collision occurs. The base station returns the reservation status 'ACDABA-F', indicating that the reservation of slot seven failed (still indicated as free) and that nothing has changed for the other slots. Again, stations can compete for this slot. Additionally, station D has stopped sending in slot three and station F in slot eight. This is noticed by the base station after the second frame. Before the third frame starts, the base station indicates that slots three and eight are now idle. Station F has succeeded in reserving slot seven as also indicated by the base station.

As soon as a station has succeeded with a reservation, all future slots are implicitly reserved for this station. This ensures transmission with a guaranteed data rate. The slotted aloha scheme is used for idle slots only; data transmission is not destroyed by collision.

**Reservation TDMA**

In a fixed TDM scheme  $N$  mini-slots followed by  $N \cdot k$  data-slots form a frame that is repeated. Each station is allotted its own mini-slot and can use it to reserve up to  $k$  data-slots.

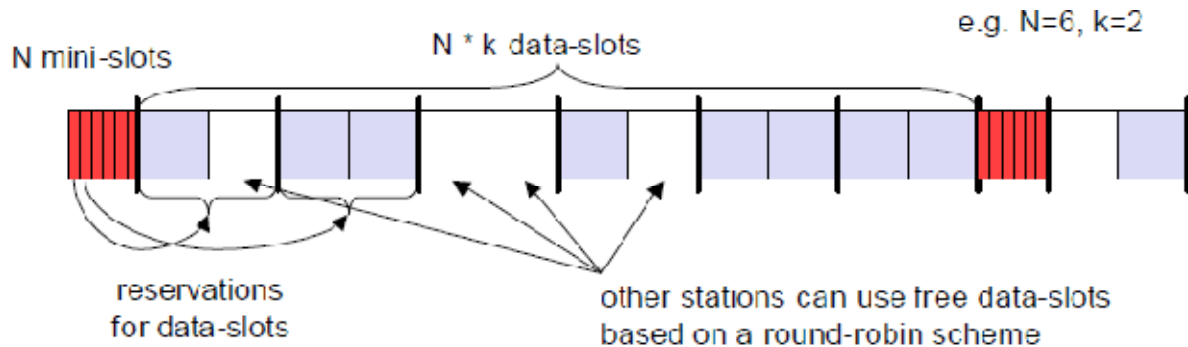

This guarantees each station a certain bandwidth and a fixed delay. Other stations can now send data in unused data-slots as shown. Using these free slots can be based on a simple round-robin scheme or can be uncoordinated using an Aloha scheme. This scheme allows for the combination of, e.g., isochronous traffic with fixed bitrates and best-effort traffic without any guarantees.

**CDMA**

Code division multiple access systems apply codes with certain characteristics to the transmission to separate different users in code space and to enable access to a shared medium without interference.

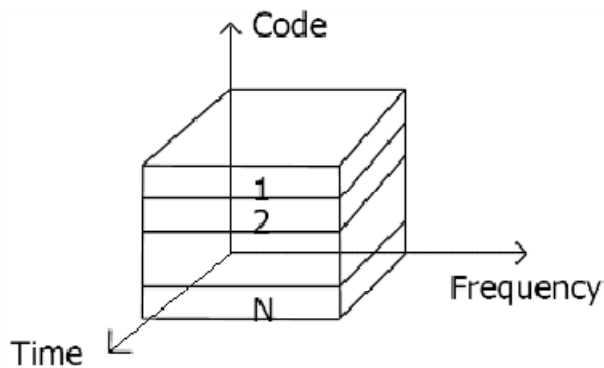

All terminals send on the same frequency probably at the same time and can use the whole bandwidth of the transmission channel. Each sender has a unique random number, the sender XORs the signal with this random number. The receiver can “tune” into this signal if it knows the pseudo random number, tuning is done via a correlation function

**Disadvantages:**



तेजस्वि नावधीतमस्तु  
ISO 9001:2008 & 14001:2004

- higher complexity of a receiver (receiver cannot just listen into the medium and start receiving if there is a signal)
- all signals should have the same strength at a receiver

**Advantages:**

- all terminals can use the same frequency, no planning needed
- huge code space (e.g. 232) compared to frequency space
- interferences (e.g. white noise) is not coded
- forward error correction and encryption can be easily integrated

**Comparison SDMA/TDMA/FDMA/CDMA**

Approach	SDMA	TDMA	FDMA	CDMA
Idea	segment space into cells/sectors	segment sending time into disjoint time-slots, demand driven or fixed patterns	segment the frequency band into disjoint sub-bands	spread the spectrum using orthogonal codes
Terminals	only one terminal can be active in one cell/one sector	all terminals are active for short periods of time on the same frequency	every terminal has its own frequency, uninterrupted	all terminals can be active at the same place at the same moment, uninterrupted
Signal separation	cell structure, directed antennas	synchronization in the time domain	filtering in the frequency domain	code plus special receivers
Advantages	very simple, increases capacity per km <sup>2</sup>	established, fully digital, flexible	simple, established, robust	flexible, less frequency planning needed, soft handover
Dis-advantages	inflexible, antennas typically fixed	guard space needed (multipath propagation), synchronization difficult	inflexible, frequencies are a scarce resource	complex receivers, needs more complicated power control for senders
Comment	only in combination with TDMA, FDMA or CDMA useful	standard in fixed networks, together with FDMA/SDMA used in many mobile networks	typically combined with TDMA (frequency hopping patterns) and SDMA (frequency reuse)	still faces some problems, higher complexity, lowered expectations; will be integrated with TDMA/FDMA

**Multiple access with collision avoidance:-**

**Multiple Access with Collision Avoidance (MACA)** is a slotted media access control protocol used in wireless LAN data transmission to avoid collisions caused by the hidden station problem and to simplify exposed station problem.

The basic idea of MACA is a wireless network node makes an announcement before it sends the data frame to inform other nodes to keep silent. When a node wants to transmit, it sends a signal called *Request-To-Send* (RTS) with the length of the data frame to send. If the receiver allows the transmission,

it replies the sender a signal called *Clear-To-Send* (CTS) with the length of the frame that is about to receive.

Meanwhile, a node that hears RTS should remain silent to avoid conflict with CTS; a node that hears CTS should keep silent until the data transmission is complete.

WLAN data transmission collisions may still occur, and the MACA for Wireless (MACAW) is introduced to extend the function of MACA.

**polling** :- In electronic communication, 'polling' is the continuous checking of other programs or devices by one program or device to see what state they are in, usually to see whether they are still connected or want to communicate.

### Inhibit Sense Multiple Access (ISMA)

Compared to ALOHA or CSMA, the Inhibit Sense Multiple Access (ISMA) radio system is supplemented by an outbound signaling of the status of the channel: either "busy" or "idle". An example of such protocol is used in the US CDPD system. When the base station receives an inbound packet, a "busy" signal is broadcast to all mobiles to inhibit them from transmission. In a practical system, this only occurs after a short processing delay  $d_1$ . The effect of this delay depends on its magnitude relative to the duration of the data packet.. After termination of (all contending) transmissions, the base station starts transmitting an "idle" signal after a delay of duration  $d_2$ .

In CSMA, the delay is mainly caused by the time a mobile terminal takes to switch from reception to transmission mode (power-up), after sensing the radio channel for carriers from other active terminals.

The busy period is defined as the period during which the base station broadcasts a busy signal plus the preceding signaling delay  $d_1$ . For memory less Poisson arrivals, the duration of the idle period, i.e., the time interval starting at the release of the channel until the first packet arrival is exponentially distributed with mean  $I = 1/G$ .

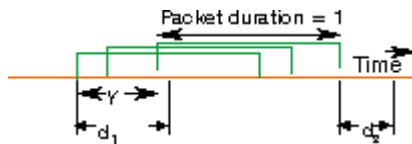

The busy period is the time interval between the first arrival of a packet until the moment that the channel becomes idle. During the initial period  $d_1$  of the busy period the outbound channel thus still reports an idle inbound channel. The duration of the busy period is at least  $1 + d_2$ , but may be longer if a collision is caused by a packet arrival in during the inhibit delay. Moreover, persistent terminals, that sense a busy signal, may start to transmit immediately after the channel becomes idle. In such cases the busy period has a duration longer than two (or more) units of time.

### No persistent ISMA



For no persistent CSMA and ISMA, rescheduling (with random back-off time) always occurs if the channel is busy at the instant of sensing. So, if a packet arrives at a nonpersistent terminal when the base station transmits a "busy" signal, the attempt is considered to have failed. If the feedback channel (or in CSMA the channel sensing mechanism) is imperfect, a transmission may erroneously be started in the period. The packet is rescheduled for later transmission.

### 1 - Persistent ISMA

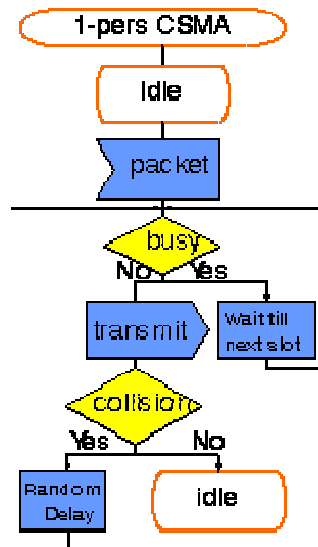

Figure: Description of terminal behavior in 1-persistent ISMA/CSMA random access network

### *p* - Persistent ISMA

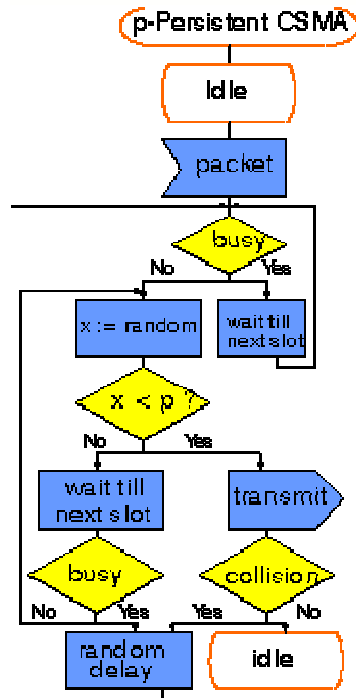

Figure: Description of terminal behavior in  $p$ -persistent ISMA/CSMA random access network

### Mobile communications:-

When you are away from the office, you may need to keep in touch with things in various ways: by telephone or email, or by using your appointments diary.

There are now many devices on the market designed to enable communications while on the move: the mobile phone, the Smartphone, tablet devices, the Personal Digital Assistant (PDA), and Wi-Fi, or 3G cards for use in your laptop computer, to name but a few. On top of that, the combinations of features that can be used together can be very confusing.

You need to consider a number of things before purchasing a mobile device and/or service. What facilities do you need? Do you need to check your St Andrews email account when you are away from your office? Would you like to view and keep your University diary up to date in your office, or remotely? Do you need web or Internet access? Would you like GPS and satellite navigation facilities? You need to decide what is important before spending the University's money. Some things may be desirable, but are they really necessary? Please refer to the table below for a rough guide to the facilities available in each type of device:

Phone Email Web Diary Other\*

Device

Mobile phone	yes	no	no	no	no
Mobile phone with enhanced services	yes	yes	yes	yes <sup>+</sup>	no
Smartphone	yes	yes	yes	yes	yes
Tablet	no	yes	yes	yes	yes

### (Global System for Mobile Communication GSM)

Global system for mobile communication (GSM) is a globally accepted standard for digital cellular communication. GSM is the name of a standardization group established in 1982 to create a common European mobile telephone standard that would formulate specifications for a pan-European mobile cellular radio system operating at 900 MHz. It is estimated that many countries outside of Europe will join the GSM partnership.

**SERVICES:** - GSM has much more to offer than voice telephony. Additional services allow you greater flexibility in where and when you use your phone. You should contact your local GSM network operator for information on the specific services available to you.

But there are three basic types of services offered through GSM which you can ask for:

- Telephony (also referred to as Teleservice) Services
- Data (also referred to as bearer services) Services.
- Supplementary Services

### Teleservices or Telephony Services:

A Teleservice utilizes the capabilities of a Bearer Service to transport data, defining which capabilities are required and how they should be set up.

### Voice Calls:

The most basic Teleservice supported by GSM is telephony. This includes Full-rate speech at 13 Kbps and emergency calls, where the nearest emergency- service provider is notified by dialing three digits. A very basic example of emergency service is 911 services available in USA.

### Videotext and Facsimile:

Another group of tele services includes Videotext access, Teletex transmission, Facsimile alternate speech and facsimile Group 3, Automatic facsimile Group 3 etc.

### Short Text Messages:

SMS (Short Messaging Service) service is a text messaging which allow you to send and receive text messages on your GSM Mobile phone. Services available from many of the world's GSM networks today - in addition to simple user generated text message services - include news, sport, financial, language and location based services, as well as many early examples of mobile commerce such as stocks and share prices, mobile banking facilities and leisure booking services.

### Bearer Services or Data Services

Using your GSM phone to receive and send data is the essential building block leading to widespread mobile Internet access and mobile data transfer. GSM currently has a data transfer rate of 9.6k. New developments that will push up data transfer rates for GSM users are HSCSD (high speed circuit switched data) and GPRS (general packet radio service) are now available.

### Supplementary Services

Supplementary services are provided on top of teleservices or bearer services, and include features such as caller identification, call forwarding, call waiting, multi-party conversations, and barring of outgoing (international) calls, among others. A brief description of supplementary services is given here:

- **Multiparty Service or conferencing:** The multiparty service allows a mobile subscriber to establish a multiparty conversation. that is, a simultaneous conversation between three or more subscribers to setup a conference call. This service is only applicable to normal telephony.
- **Call Waiting:** This service allows a mobile subscriber to be notified of an incoming call during a conversation. The subscriber can answer, reject, or ignore the incoming call. Call waiting is applicable to all GSM telecommunications services using a circuit-switched connection.
- **Call Hold:** This service allows a subscriber to put an incoming call on hold and then resume this call. The call hold service is only applicable to normal telephony.
- **Call Forwarding:** The Call Forwarding Supplementary Service is used to divert calls from the original recipient to another number, and is normally set up by the subscriber himself. It can be used by the subscriber to divert calls from the Mobile Station when the subscriber is not available, and so to ensure that calls are not lost. A typical scenario would be a salesperson turns off his mobile phone during a meeting with customers, but does not wish to lose potential sales leads while he is unavailable.
- **Call Barring:** The concept of barring certain types of calls might seem to be a supplementary disservice rather than service. However, there are times when the subscriber is not the actual user of the Mobile Station, and as a consequence may wish to limit its functionality, so as to limit the charges incurred. Alternatively, if the subscriber and user are one and the same, the Call Barring may be useful to stop calls being routed to international destinations when they are routed. The reason for this is because it is expected that the roaming subscriber will pay the charges incurred

for international re-routing of calls. So, GSM devised some flexible services that enable the subscriber to conditionally bar calls.

- **Number Identification:** There are following supplementary services related to number identification:
  - **Calling Line Identification Presentation:** This service deals with the presentation of the calling party's telephone number. The concept is for this number to be presented, at the start of the phone ringing, so that the called person can determine who is ringing prior to answering. The person subscribing to the service receives the telephone number of the calling party.
  - **Calling Line Identification Restriction:** A person not wishing their number to be presented to others subscribes to this service. In the normal course of event, the restriction service overrides the presentation service.
  - **Connected Line Identification Presentation:** This service is provided to give the calling party the telephone number of the person to whom they are connected. This may seem strange since the person making the call should know the number they dialled, but there are situations (such as forwardings) where the number connected is not the number dialled. The person subscribing to the service is the calling party.
  - **Connected Line Identification Restriction:** There are times when the person called does not wish to have their number presented and so they would subscribe to this person. Normally, this overrides the presentation service.
  - **Malicious Call Identification:** The malicious call identification service was provided to combat the spread of obscene or annoying calls. The victim should subscribe to this service, and then they could cause known malicious calls to be identified in the GSM network, using a simple command. This identified number could then be passed to the appropriate authority for action. The definition for this service is not stable.
- **Advice of Charge (AoC):** This service was designed to give the subscriber an indication of the cost of the services as they are used. Furthermore, those Service Providers who wish to offer rental services to subscribers without their own Subscriber Identity Module (SIM) can also utilize this service in a slightly different form. AoC for data calls is provided on the basis of time measurements.
- **Closed User Groups (CUGs):** This service is provided on GSM to enable groups of subscribers to only call each other. This type of services is being offered with special discount and is limited only to those members who wish to talk to each other.
- **Unstructured supplementary services data (USSD):** This allows operator-defined individual services.

## System Architecture

A GSM Public Land Mobile Network (PLMN) consists of at least one Service Area controlled by a Mobile Switching Center (MSC) connected to the Public Switched Telephone Network (PSTN), see Figure gsm1.

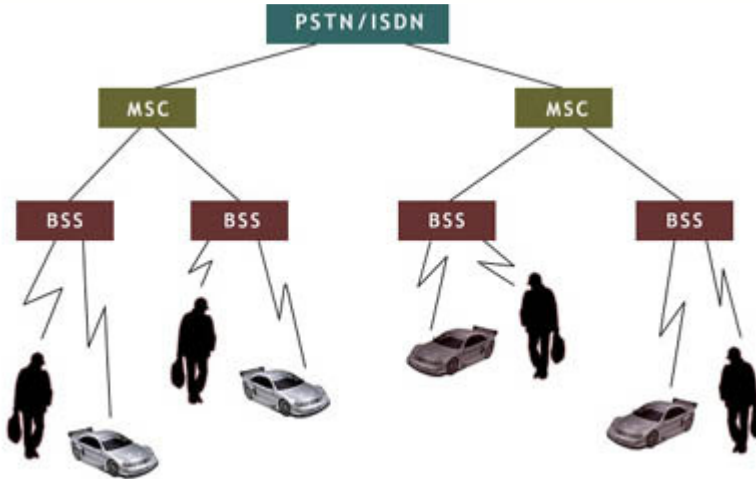

Figure gsm1. The architecture of a GSM Public Land Mobile Network (PLMN)

A Base Station Subsystem (BSS) consists of

- a Base Station Controller (BSC)
- at least one radio access point or Base Transceiver Station (BTS) for Mobile Stations (MS), which are mobile phones or other handheld devices (for example PDA computers) with phone interface.

A BTS, with its aerial and associated radio frequency components, is the actual transmission and reception component. A Network Cell is the area of radio coverage by one BTS. One or more BTSs are in turn managed by a BSC. A network cell cluster covered by one or several BSSs can be managed as a Location Area (LA). All these BSSs must however be controlled by a single MSC. In Figure gsm2 is shown three LAs of 3, 4 and 4 cells respectively with a MS moving across cell and LA boundaries.

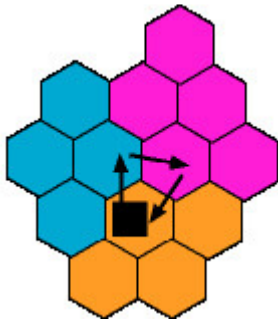

Figure gsm2. A MS moving across cell and LA boundaries. 3 LAs consisting of 4 and 5 cells respectively are shown.



A more detailed architecture of a single MSC controlled Service Area is outlined in Figure gsm3.

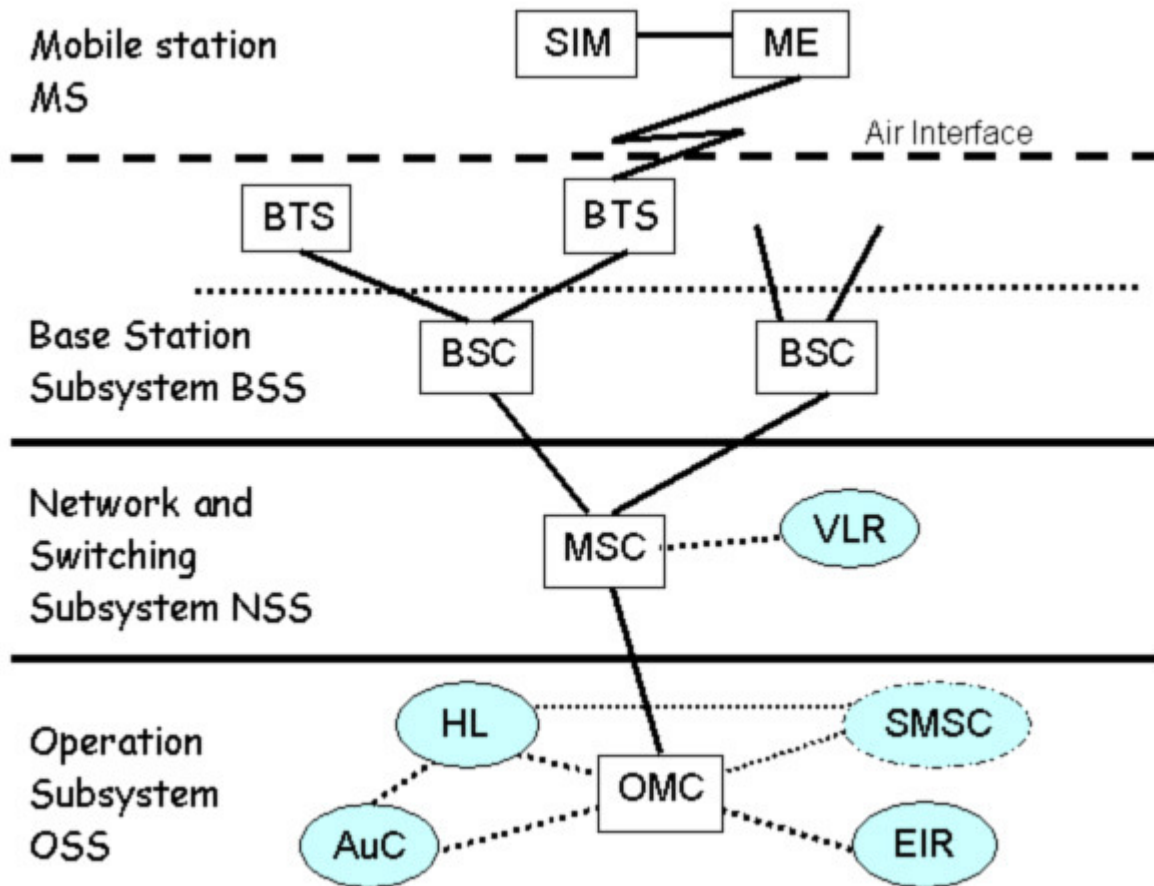

Figure gsm3. The GSM network architecture for a single MSC controlled Service Area

The components of the tree GSM network subsystems

- Radio Subsystem (RSS) consisting of the BSSs and all BSS connected MS devices .
- Network and Switching Subsystem (NSS)
- Operation Subsystem (OSS)

specified in GSM 01.02 ('General description of a GSM Public Land Mobile Network(PLMN)') and the GSM components

- ME** = Mobile Equipment
- BTS** = Base Receiving Station
- BSC** = Base Station Controller
- MSC** = Mobile Switching Center
- VLR** = Visitor Location Register
- OMC** = Operation and Maintenance Center
- AuC** = Authentication Center
- HLR** = Home Location Register
- EIR** = Equipment Identity Register
- SMSC** = Short Message Service Centre

are shown in Figure gsm3.

A MSC is also through a Gateway MSC (GMSC) connected to other MSCs and to the Public Switched Telephone Network (PSTN) with the Integrated Services Digital Network (ISDN) option. The Inter-Working Function (IWF) of GMSC connects the circuit switched data paths of a GSM network with the PSTN/ISDN. A GMSC is usually integrated in an MSC, see Figure gsm.

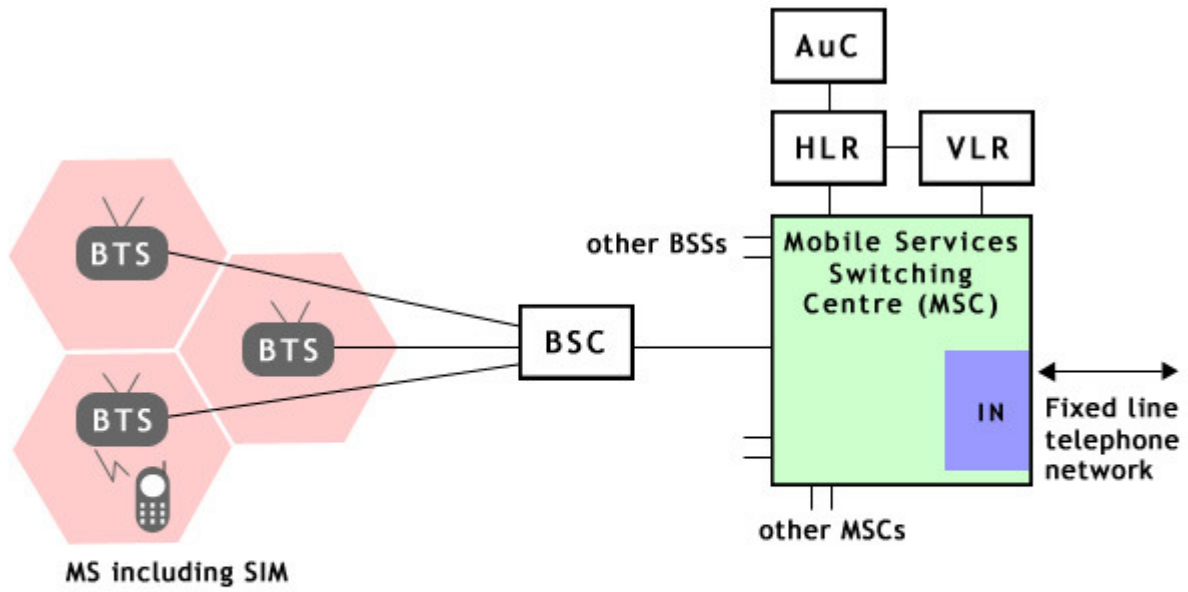

*Mobile Station = MS*  
*Subscriber Identity Module = SIM*  
*Base Transceiver Station = BTS*  
*Base Station Controller = BSC*

*HLR = Home Location Register*  
*VLR = Visited Location Register*  
*AuC = Authentication Centre*  
*IN = Interrogating Node*

*Figure gsm. Basic GSM network components*

### Network and Switching Subsystem (NSS)

NSS consists of the Mobile Switching Center (MSC) and the Visitor Location Register (VLR). A MSC manages multiple BSSs and is responsible for

- setting up, managing and shutting down connections,
- handling call charges
- supervising supplementary services, such as call forwarding, call blocking and conference calling.

VLR contains information about all MSs currently within range of the associated MSC. This information is needed for routing a call to a particular MS (mobile telephone) via the proper BSS and radio cell. The VLR also maintains a list of MSs belonging to subscribers of other GSM networks. Such subscribers have logged or roamed into the network of the associated MSC. The area covered by a MSC is actually called a MSC/VLR Service Area , which can consist of several LAs as is shown in Figure gsm5.

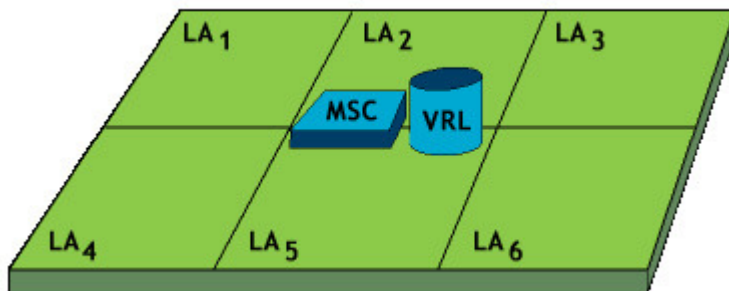

Figure gsm5. A MSC/VLR Service Area

## Operation Subsystem (OSS)

The OSS consists of

- the Operation and Maintenance Center (OMC)
- the Authentication Center (AuC),
- the Home Location Register (HLR)
- the Equipment Identity Register (EIR).

OMC is responsible for

- regular network operation
- subscriber administration
- call billing.

AuC is the security component on the network side. AuC generates and manages all cryptographic keys and algorithms needed for network operation, especially for authentication of the MSs (i.e., the SIMs). HLR contains all of the subscriber data as well as the localization data for each of the MS. EIR contains essential data, such as the serial numbers of all MSs represented in the network. OSS also controls the Short Message Service Centre (SMSC) for transmission of SMS messages. SMSC need information in HLR for the routing of SMS messages.

## GSM Network Areas

In GSM, there is a strong distinction between subscribers, which are identified by their SIM, and the hardware they use for making phone calls and data communication calls. For identification both entities before and during GSM service allocation, several identification numbers exist and are stored in HLR, VLR and EIR.

The following identification numbers are stored in the HLR:

- **International Mobile Subscriber Identity (IMSI)**, a permanent ID assigned to each GSM network subscriber.
- **International Mobile Subscriber ISDN Number (MSISDN)**, the ISDN number (phone number) permanently assigned to each GSM subscriber.
- **Mobile Station Roaming Number (MSRN)**, a temporary ISDN number of a subscriber. This number is assigned by the local VLR each time, the subscriber enters its MSC/VLR area. The MSRN is then sent to

the HLR and to the GMSC.

- **The address of current VLR and MSC** (if available), an address of the area the subscriber is currently in.
- **Local Mobile Subscriber Identity** (if available), a short ID temporarily assigned to an active subscriber by an VLR and sent to the HLR.

The following identification numbers are stored temporarily at the VLR associated with the MSC which is currently controlling an active MS:

- **IMSI**
- **MSISDN**
- **MSRN**
- **Location Area Identity (LAI)**, the ID of the Location Area (LA), in which subscriber is or has been connected to a GSM network.
- **Temporary Mobile Subscriber Identity (TMSI)**, temporarily assigned to an active MS in order to prevent the IMSI from being transmitted too often over the radio interface. The TMSI is periodically changed during a call.

Equipment Identity Register (EIR) is a database for mobile equipment information of all subscribers. In this database, three lists (white, black and gray) store identification numbers, which are unique to all mobile terminals. The white list contains allowed terminals, the black list contains unallowed terminals (e.g. stolen or lost), and the gray contains terminals with known bugs.

### **GSM Network Areas**

The area covered by one GSM operator is called the PLMN Service Area, which can consist of several MSC/VLR Service Areas as shown in Figure gsm6. A typical PLMN Service Area is thus the area of a country, a state, or a region. A GSM Network Area is thus a hierarchy with the levels

- PLMN Service Area
- MSC/VLR Service Area, see Figure gsm5
- Location Area (LA), see Figure gsm2
- Network Cell.

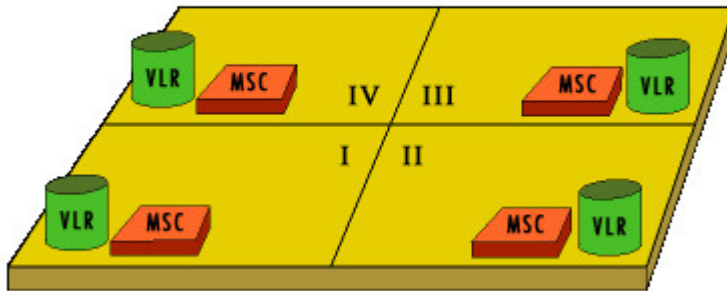

Figure gsm6. A PLMN Service Area for a GSM operator

## GSM: Radio interface

One of the main objectives of GSM is roaming. Thus, to allow for interoperability between MNs stations and disparate networks of the radio interface must be standardised. Spectrum efficiency depends on aspects of the radio interface and transmission, such as system capacity or techniques used to optimize SIR and frequency reuse. It thus, becomes clear that the specification of the radio interface can influence the spectrum efficiency.

## Frequency allocation

Two frequency bands, of 25 Mhz each, are allocated for the GSM system:

- 890-915 Mhz for the uplink (MN to BTS).
- 935-960 Mhz for the downlink (BTS to M).

However, for reasons related to the military as well as the existence of past analog systes (that use part of the two frequency bands), not all the countries can use the whole GSM frequency bands.

## Medium access

GSM employs a mix of Frequency Division Multiple Access (FDMA) and Time Division Multiple Access (TDMA), combined with frequency hopping.

Using FDMA, a frequency is assigned to **each** user. So for **large** number of users in a FDMA system, the **larger** the number of required frequencies. The limited available radio spectrum and the fact that a user will not free its assigned frequency until he does not need it anymore, reasons about scalability problems in an FDMA system.

TDMA allows several users to share the **same** channel. Each subscriber multiplexes the shared channel, scheduling their frame for transmission. Usually TDMA is used with an FDMA structure.



In GSM, a 25 Mhz frequency band is divided, using a FDMA scheme, into **124** carrier frequencies with a 200khz spacing. Normally a 25 Mhz frequency band can provide 125 carrier frequencies; however, the **first** carrier frequency is used as a **guard-band** between GSM and other services working on lower freq. band. Each carrier is time-divided using a TDMA scheme. This scheme **splits** a 200khz channel, into 8 **bursts**. A burst is the unit of time in a TDMA system, and it lasts approximately **0.577ms**. Thus a TDMA lasts **4.615ms**. Each burst is assigned to a **single** user.

### Channel structure

A channel maps to the recurrence of one burst every frame. It is defined by its frequency and the position of its corresponding burst within a TDMA frame. In GSM there are two types of channels:

- traffic channels used for speech and data.
- control channels used for network management messages and channel maintenance tasks.

### Traffic channels (TCH)

**Full-rate** traffic channels (TCH/F) are defined using a group of 26 TDMA frames called a **26-Multiframe**. The 26-Multiframe lasts 120 ms. In this frame group traffic channels for the downlink and uplink are **separated** by 3 bursts. That implies, the mobiles will not need to transmit and receive at the same time which simplifies considerably the electronics of the system.

The frames that form the 26-Multiframe structure have different functions:

- 24 frames are reserved to traffic.
- 1 frame is used for the Slow Associated Control Channel (SACCH).
- The last frame is unused. It allows the MN to perform other functions, such as measuring the signal strength of neighboring cells.

**Half-rate** traffic channels (TCH/H), which double the capacity of the system, are also grouped in a 26-Multiframe but the internal structure is different.

### Control channels

According to their functions, 4 different classes of control channels are defined:

#### Broadcast channels (BCH)

The BCH channels are used, by BTS to provide the MN with synchronization information from the network. 3 different types of BCHs can be distinguished:

- **Broadcast Control Channel (BCCH):** gives to the MN the parameters needed to identify and access the network.

- **Synchronization Channel (SCH):** gives the MN the training symbol sequence to demodulate the information transmitted by BTS.
- **Frequency-Correction Channel (FCCH):** provides the MN with the frequency reference of the system for the purposes of synchronization.

### Common Control Channels (CCCH)

The CCCH channels help to establish the call from the mobile station or the network. These are:

- **Paging Channel (PCH):** used to alert the MN of an incoming call.
- **Random Access Channel (RACH):** used by the MN to request network access.
- **Access Grant Channel (AGCH):** used, by the BTS, to inform the MN about the channel it should use. This channel is the answer of a BTS to a RACH request from the MN.

### Dedicated Control Channels (DCCH)

The DCCH channels are used for message exchange between several mobiles or a mobile and the network. These are:

- **Standalone Dedicated Control Channel (SDCCH):** used to exchange signaling in the downlink and uplink.
- **Slow Associated Control Channel (SACCH):** used for channel maintenance and control.

### Associated Control Channels (ACCH)

**Fast** Associated Control Channels (FACCH) **replaces** all or part of a traffic channel when urgent signaling must be transmitted. The FACCH channels carry the same signaling as SDCCH channels.

### Burst structure

Four different types of bursts can be distinguished in GSM:

- **Frequency-correction**, used on the FCCH. It has the same length as the normal one but a *different* structure.
- **Synchronization** burst used on the SCH. It has the same length as the normal one but a different structure.
- **Random access** used on the RACH and is **shorter** than the normal burst.
- **Normal** burst used to carry speech or data information. It lasts approximately 0.577 ms and has a length of **156.25 bits**. Its structure is presented below.

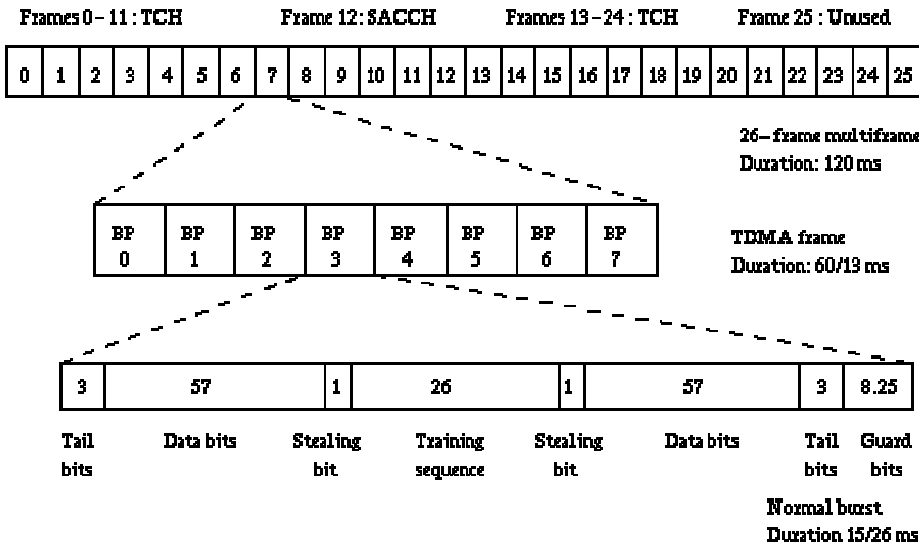

*Structure of the 26-Multiframe, the TDMA frame and the normal burst*

The **tail bits** (T) are a group of 3 bits set to zero and placed at the *beginning* **and** the *end* of a burst. They cover the periods of ramping up and down of the mobile's **power**.

The coded **data bits** corresponds to two groups, of **57 bits** each, containing signaling or user data.

The **stealing flags** (S) indicate, to the receiver, whether the data bits are data or signaling traffic.

The training sequence has a length of **26 bits**. It synchronizes the receiver, thus masking out multipath propagation effects.

The **guard period** (GP), with a length of **8.25 bits**, is used to *avoid a possible overlap* of two mobiles during the ramping time.

**Elementary Knowledge on Satellite systems:**

The Merriam-Webster dictionary defines a satellite as a celestial body orbiting another of larger size or a manufactured object or vehicle intended to orbit the earth, the moon, or another celestial body.

Today's satellite communications can trace their origins all the way back to the Moon. A project named communication moon relay was a telecommunication project carried out by the United States Navy. Its objective was to develop a secure and reliable method of wireless communication by using the Moon as a natural communications satellite.

The first artificial satellite used solely to further advances in global communications was a balloon named Echo 1. Echo 1 was the world's first artificial communications satellite capable of relaying signals to other points on Earth. It soared 1,000 miles (1,609 km) above the planet after its Aug. 12, 1960 launch, yet relied on humanity's oldest flight technology — ballooning. Launched by NASA, Echo 1 was a giant metallic balloon 100 feet (30 meters) across. The world's first inflatable satellite — or "satelloon," as they were informally known — helped lay the foundation of today's satellite communications. The idea behind a communications satellite is simple: Send data up into space and beam it back down to another spot on the globe. Echo 1 accomplished this by essentially serving as an enormous mirror 10 stories tall that could be used to bounce communications signals off of.

The first American satellite to relay communications was project scope in 1958, which used a tape recorder to store & forward voice messages. It was used to send a Christmas greeting to the world from U.S. President Dwight D. Eisenhower. NASA launched the Echo satellite in 1960; the 100-foot (30 m) aluminised PET film balloon served as a passive reflector for radio communications. Courier 1B, built by Philco, also launched in 1960, was the world's first active repeater satellite.

Applications:-

- 1) Telephone
- 2) Digital cinema
- 3) Radio
- 4) Military
- 5) Internet access

**BASICS:-**

Satellite Systems can be classified based upon their orbits as low earth orbit, medium earth orbit & geostationary earth orbit systems. Geostationary is also the highest earth orbit and hence, also provides the greatest visibility using only a few satellites. The coverage region of a satellite is called its footprint. This is the region from which the satellite is visible. Three geostationary satellite footprints ensure complete coverage of the earth as shown:

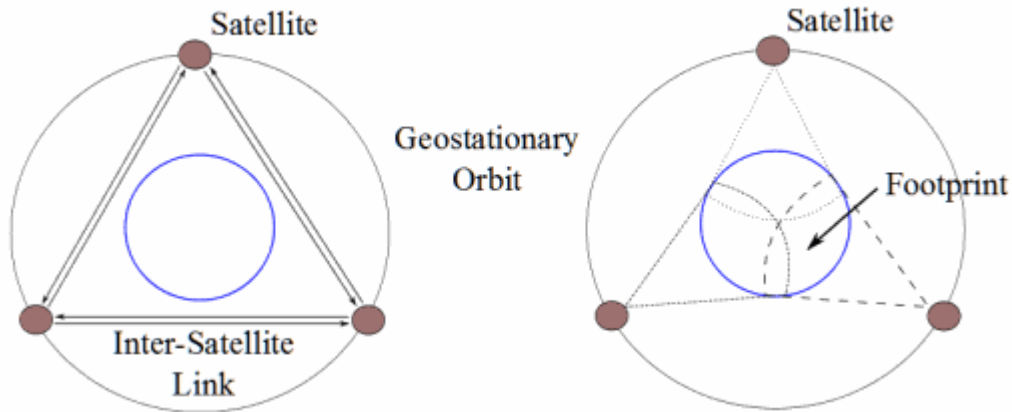

Hence, there is permanent or 24 hour visibility of geostationary satellites without the need of handoffs. While LEO & MEO satellites do not have 24 hour visibility as the satellites have smaller footprints since they are closer to the earth (low satellite height). Hence, a larger number of satellites are needed to cover the earth. Also, since each satellite has a small footprint, handoffs are also required between satellites.

Major differences between LEO, MEO & GEO satellite systems:

Parameter	LEO	MEO	GEO
Satellite Height	500-1500 km	5000-12000 km	35,800 km
Orbital Period	10-40 minutes	2-8 hours	24 hours
Number of Satellites	40-80	8-20	3
Satellite Life	Short	Long	Long
Number of Handoffs	High	Low	Least(none)
Gateway Cost	Very Expensive	Expensive	Cheap
Propagation Loss	Least	High	Highest

## **Routing:-**

**Routing** is the process of selecting paths in a network along which to send network traffic. Routing is performed for many kinds of networks, including the telephone network (circuit switching), electronic data networks (such as the Internet), and transportation networks. This article is concerned primarily with routing in electronic data networks using packet switching technology.

In packet switching networks, routing directs packet forwarding (the transit of logically addressed packets from their source toward their ultimate destination) through intermediate nodes. Intermediate nodes are typically network hardware devices such as routers, bridges, gateways, firewalls, or switches. General-purpose computers can also forward packets and perform routing, though they are not specialized hardware and may suffer from limited performance. The routing process usually directs forwarding on the basis of routing tables which maintain a record of the routes to various network destinations. Thus, constructing routing tables, which are held in the router's memory, is very important for efficient routing. Most routing algorithms use only one network path at a time. Multipath routing techniques enable the use of multiple alternative paths.

## UNIT-III

### Introduction – the Mobile Internet

#### Forget first generation WAP

We call it the 'Mobile Internet' these days to differentiate between the latest and the first Versions of the protocol used to deliver a web experience on the mobile phone (i.e. WAP or Wireless Application Protocol). WAP 1.0 was black & white and very slow whereas the latest generation of WAP (2.0) is based on the same XHTML standards (Extensible Hypertext Mark-up Language) used by PC browsers such as IE and Firefox and supports mobile internet sites and applications.

#### WAP 2.0 gives a superb, interactive online experience in full color

For the non-technical, WAP 2.0 gives a mobile internet experience that uses the full colour range of the handset screen, allows forms (text boxes) to be completed and submitted, enable links to be followed and applies a set of standards that should ensure all handsets render a high quality mobile internet website (or WAP site). Since 2003 most mobiles have adopted WAP2.0 for rendering mobile internet sites and in the last two years a consensus has emerged that mobile internet sites should be tall and thin like the image to the left.

#### Do I need two internet sites?

The beauty of the new standards is that, when written properly, one website should load correctly on a PC as well as old and new mobile phones and PDAs. This means you need only one website– a single URL or web address –and should have to maintain only one set of content. This does however assume some fore thought has been employed during design. Of course what you see on different devices will look different since screen orientations and sizes vary, even though one set of code is delivering multiple versions of the site. Take a look at the Incentivized website on your PC and mobile for example. When you open the page our web server determines.

#### Implementing WAP Services:-

A significant difference between WML and HTML is that WML supports *variables*. WML variables contain strings, and these strings can be inserted into the body text of the WML document or into the values of certain attributes. The values of variables can be changed under the control of the WML itself and also from within WML Script functions.

#### Variable Substitution

Variables can be inserted (or *substituted*) into the body text or an attribute value in one of three ways:

\$name  
\$(name)  
\$(name:conversion)

#### Setting Variables

You now know just about everything there is to know about actually using WML variables, but one thing you don't yet know is how to put useful values into the variables in the first place!

Actually, there are three ways. The most common is through the use of the various user interface elements, which are described. Variables can also be set from WMLScript, as explained. The third way is with the <setvar> element.



## Browser Contexts

The *browser context* in WML is the set of all variables currently set, together with the *history stack* (the list of all the cards the user has recently visited).

The context is emptied (all variables are unset, and the stack is emptied) when a card is displayed with the new context attribute set to true for more on cards and their attributes.

## WML Tasks and Events

In the last chapter, you learned about variables in WML, something not found in HTML. This chapter covers two further parts of WML—tasks and events—that have no real equivalent in HTML. (In some cases you can use JavaScript to achieve similar effects.)

## WML User Interaction

The previous two chapters described some of the features found in WML that don't exist in HTML. This chapter covers the features that WML provides to receive input from the user, and most of these are much more powerful than their equivalents in HTML.

The main reason for this extra power is that WML has variables. In HTML, you can have controls such as pulldown menus or text input fields, but you can use these in only limited ways: in an HTML *form*, which allows you to collect a number of controls and send their results to a server for processing, or with Java or JavaScript, which are complete programming languages built into the web browser.

## Problems with Web Interaction

Using HTML forms for this purpose suffers from one major problem: the processing has to be done on the server. The client displays the controls, collects their results, packages them, and sends them to the server, but that's it. Apart from some simple constraints such as the maximum length of the text in an input box, you can't even check the input for validity before sending it off. This results in a lot of extra network connections, slowing things down a lot, even on a fast Internet link. Imagine how slow all those extra network connections are on a much slower link, as WAP has to contend with.

Using Java or JavaScript to collect the input does allow local processing, but they come complete with their own sets of problems. For a start, they both require a lot more from the browser: most older browsers have either no support for these or very limited or buggy support, which makes it harder to write pages that work across all browsers. Most text-only browsers don't support these at all. (Yes, some people do still use text-only browsers.)

Another, subtler problem with the Web's way of doing these things is that there are multiple ways to declare the controls. Suppose you want to display a text input box. Using a form, you can use something like:

```
<INPUT TYPE="TEXT" NAME="wibble">
```

Using JavaScript with the HTML, possibly:

```
<INPUT TYPE="TEXT" NAME="wibble" ONCHANGE="wibble_chg( );">
```

If using Java applets, something like:<sup>[1]</sup>

<sup>[1]</sup> It isn't completely fair to compare Java with HTML here, since Java is a full-featured programming language, and HTML is just a markup language. But since Java is often used to implement this sort of thing on web pages, it's appropriate to mention it here.

```
TextField wibble = new TextField ( );  
add (wibble);
```

Each of these fragments has to be referenced in a completely different way from within the HTML page that forms the skeleton. Furthermore, the same control has to be added to the page in three different ways, even though they are all drawn in the same way by the browser, and the user interacts with each in the same way. This makes it hard to change the action of a control once it has been implemented. It requires rewriting everything related to that control, and probably restructuring the whole page as well.

### Interaction in WAP

For comparison, here is how the same text input box is described in WML, where its result is sent directly to the server:

```
<input name="wibble"/>
```

Here, its result is passed to some WMLScript to check it for validity before passing it to the server:

```
<input name="wibble"/>
```

Here, it's displayed to the user in another card for confirmation purposes, without any server transactions involved:

```
<input name="wibble"/>
```

These three examples are identical because the same control is always written in the same way in WML. Doing it this way works because none of the controls ever perform any direct action. They are instead linked to the lower-level layers of WML, such as variables and tasks.

For example, in the previous <input> element, the only effect of the user entering some text into the box is that the variable wibble is set to a new value. The browser doesn't directly send the text to the server or call any scripts: it's up to you to use the value of this variable at some point.

### Elements:-

#### The <input> Element

Let's start our exploration of WML's mechanisms for user interaction with the <input> element, since we've just seen it in action.

This element is used whenever the user needs to enter a string or some other piece of text. Usually, this should be kept as short as possible, since many WAP users use cell phone keypads to enter these. Entering the letter S on a computer keyboard is easy, but this requires four keypresses on most cell phones. Symbols are even worse: with the exception of a few, such as . and +, symbols are very time-consuming to enter.

The `<input>` element can also be used to enter passwords or other sensitive information. In these cases, the element can be configured to not display the text as it's being entered. (In the case of cell phones, most display each character for a short time but then replace it with a \* or other symbol.)

This element is also used for entering numbers. In cases like this, where the range of characters is restricted, it's possible to set a *format* for the string, which may speed up input. To do so, set the format to allow only digits; a cell phone knows that the keys don't need to cycle through all the letters before offering a digit (the digits are accessed with a single keypress instead of four or more).

This element (as with all user interaction elements) may be put anywhere in normal paragraph text (namely, inside a `<p>` element). It takes nine attributes, most of which are optional.

### The `<select>` Element

The other high-level control that WML provides is one allowing selection from a list of items. This replaces many different types of control, such as scrolling selectable lists, pulldown menus, and lists of checkboxes.

In its simplest form, the `<select>` element provides an `iname` attribute giving a WML variable name. Inside the `<select>` is a list of `<option>` elements. Selecting an option sets the `iname` variable to the index of that item within the `<select>`, starting from 1. For example:

```
<select iname="animal">
  <option>Lizard</option>
  <option>Spider</option>
  <option>Squid</option>
</select>
```

Selecting Lizard sets `animal` to 1, selecting Spider sets it to 2, and selecting Squid sets it to 3.

In a slightly more complex form, the `<select>` element has a `name` attribute rather than `iname`, and a list of `<option>` elements, each of which has a `value` attribute. Selecting one of these options sets the `name` variable to the contents of the option's `value` attribute. For example, a list allowing the user to select a London airport can be written as:

```
<select name="airport">
  <option value="LHR">London Heathrow</option>
  <option value="LGW">London Gatwick</option>
  <option value="STN">London Stansted</option>
  <option value="LCY">London City</option>
  <option value="LTN">London Luton</option>
</select>
```

### The `<option>` Element

While on the subject of the `<select>` element, it's time for a closer look at the `<option>` element that is so vital to it. You've already seen the two most common ways to use this element (with or without a `value`), but it's also possible to bind a task to an option, so that the task is performed when the user selects the option (or deselects it, for a multiple-selection list).

This task is bound to the `onpick` event. It can be bound either with a conventional `<onevent>` binding, or for simple `<go>` tasks it can be specified with the `onpick` attribute on the `<option>` tag itself.

## The <optgroup> Element

WAP doesn't define how the <select> element is displayed. It has been implemented in many different ways, including using pulldown menus, scrolling lists, and lines of checkboxes on PDA-type devices and several different types of menus on cell phones.

With a small screen, it isn't always possible to display all the available options at the same time. There are several ways to get around this problem: if the options are displayed normally in the text of the page, as with checkboxes for example, then the normal facilities for scrolling the page will do. Many cell phones simply display the currently selected option; activating this for editing changes the screen to a different display with the options. When the editing is complete, the display changes back to the card.

The purpose of the <optgroup> element is to divide a long list of options into several sections. Different browsers may use this information in different ways: many simply ignore it (particularly those running on devices with large screens). Others may display the title of the group as part of the option display but not do anything more with it. Some may use the group title as the name of a submenu, with the contents of the group in that submenu. The information is a hint, nothing more.

The <optgroup> element takes only one attribute:

### The <do> Element

The <input> and <select> elements provide high-level user controls, but sometimes all you want is a simple button or menu item. In these cases, the <do> element is exactly what you need.

A <do> element is simply a way to specify some arbitrary type of control for the browser to make available to the user. This can be rendered as a graphical button (as many PDA browsers do), as an item in a menu (as most cell phone browsers do), or as just about anything the user can know about and interact with. This can even include things such as voice commands for a hands-off WAP browser (in a car, for example).

A <do> element contains nothing but the task to be performed when the element is activated

### The <anchor> Element

While the <do> element is useful, it isn't always what you want. Many cell phone browsers put all the <do> items in a card in a single menu, which means you can't guarantee it will appear where you want it to. Sometimes you want to make some of the text into an HTML-style link, rather than have a separate <do> control next to it. For example, if you have a menu of other pages available, you want the items in the menu to display in the correct order

### The <a> Element

If you've done much work with HTML, the <anchor> element may seem like a lot of typing. Sure, it's more flexible than HTML's <A> tag, but it seems much nicer to simply type:

```
<A HREF="somewhere">linked text</A>
```

than it is to type:

```
<anchor><go href="somewhere"/>linked text</anchor>
```

Fear not: the designers of WML also recognized this fact and provided WML with the `<a>` element. (The name must be a lowercase a.) It's a useful shorthand for this simple case of the `<anchor>` element, which also has the benefit of looking familiar to HTML developers. It takes two attributes:

title (optional variable string)

This has exactly the same effect as the title attribute on the `<anchor>` element. It provides an optional title for the element, which some browsers may use in displaying it. The same caveats apply: it's wise to keep the length to at most six characters, and the browser is free to ignore the attribute (as indeed most do).

href (required variable URL)

Specifies the URL to go to when the link is activated.

For example, the element:

```
<a title="Next" href="page17.wml">Next Page</a>
```

is exactly equivalent to:

```
<anchor title="Next">  
  <go href="page17.wml"/>  
  Next Page  
</anchor>
```

The form using the `<a>` element is also more efficient than the form using `<anchor>`, as there is less to transmit to the browser. Try to use the `<a>` form wherever possible.

### The **tabindex** Attribute

Some browsers can cycle through `<input>` and `<select>` in a card using some sort of TAB key or similar control. Normally, the order in which this happens is chosen by the browser (usually the order in which the elements are specified in the card). The **tabindex** attribute allows this order to be changed for some or all of the elements in a card.

Not all browsers support this feature, as it doesn't fit into all of the user interfaces. If this feature is supported, the browser sorts all the `<input>` and `<select>` elements with a **tabindex** specified in ascending order. Pressing the TAB key (or whatever normally cycles through such elements) then selects these elements in this order. Any elements in the card without a **tabindex** specified are selected last.

**Example 4.4** shows how this attribute can be used. The user is asked for a normal postal address. Both the county and nation fields have no **tabindex**: nation because it has a default, and county because it's usually unnecessary to give a county or state if the postal code is correct. The `<do>` element at the end calls a WMLScript function to check that the values are acceptable (for example, if no postal code is given, a county is required).

### Example 4.4. Use of the **tabindex** Attribute



तेजस्वि नावधीतमस्तु  
ISO 9001:2008 & 14001:2004

```
<?xml version="1.0"?>
<!DOCTYPE wml PUBLIC
  "-//WAPFORUM//DTD WML 1.1//EN"
  "http://www.wapforum.org/DTD/wml_1.1.xml">

<wml>
  <card title="Enter address">
    <p>Street:
      <input name="street" tabindex="1"/></p>
    <p>Town/City:
      <input name="town" tabindex="2"/></p>
    <p>County/State/Province:
      <input name="county"/></p>
    <p>Postal/Zip Code:
      <input name="code" tabindex="3"/></p>
    <p>Nation:
      <input name="nation" value="uk"/></p>
    <do type="accept" label="OK">
      <go href="address.wmlsc#check()"/>
    </do>
  </card>
</wml>
```

## WML Timers

The previous chapters described how to interact with users in WML. Sometimes, however, you may want something to happen without the user explicitly having to activate a control.

To take a common example, suppose you want to display a company logo when the user connects to your WAP service. On a web page, you'd keep the image for the logo on screen the whole time, but WAP devices have limited screen sizes, and you can't afford to waste the space.

## WML Decks, Templates, and Cards

Now that you've seen some of the interesting things you can put into a deck, it's time to revisit those very first WML elements we saw back. You can see them in more detail in the light of what you now know about WML; particularly events and the <do> element

## A Simple WML Example

```
<?xml version="1.0"?>
<!DOCTYPE wml PUBLIC
  "-//WAPFORUM//DTD WML 1.1//EN"
  "http://www.wapforum.org/DTD/wml_1.1.xml">

<wml>
  <card title="First WML Example">
    <p>Hello, World!</p>
  </card>
</wml>
```

### Elements:-

#### The <wml> Element

The <wml> element serves a purpose much like the <HTML> element does for HTML pages: it encloses the entirety of the deck. Effectively, a WML deck consists of a single <wml> element. It doesn't take any attributes

#### The <head> Element

The <head> element in WML is similar to the <HEAD> element in HTML: it marks a place for *meta-information* about the document to be stored. Meta-information is information about the document itself, rather than its content. If present, the <head> element must be the first thing inside the <wml> element. It doesn't take any attributes.

#### The <access> Element

The <access> element provides a simple form of *access control* for a deck. This allows a deck to specify that only certain other decks may link to it (these decks are known as *referring URLs*). Since this control is performed in the browser, not the server, there is no real security in this mechanism, and hence it's probably of limited use. There may be no more than one <access> element in a deck, and it must be the first thing inside the <head> element.

#### The <meta> Element

The <meta> element places an item of arbitrary meta-information in a WML deck. This item is structured as a *property name* and its *value*. You can put any number of <meta> elements into the <head> element. This can add keywords for indexing purposes, store hints about the content of the deck, and store any other information. No standard properties have yet been defined for WML, but conventions will develop, just as they did with HTML.

#### The <card> Element

As you saw back in the <card> element encloses a WML card within a deck. In addition, text and graphics enclosed within <p> elements, it may also contain a number of event bindings and a timer

#### The <template> Element



The `<template>` element provides an interesting WML feature not found in HTML. When you write a deck containing several cards, you may find that parts of the structure are common to all the cards. For example, it's fairly typical for each card to have a "back" control and a "home" control. These controls are normally implemented as `<do>` elements. It would be convenient to specify these common elements once per deck rather than once per card, and that is just what the `<template>` element allows.

It doesn't stop there, though. Remember all those card events from .Wouldn't it be easier to set up bindings for all the events just once for the whole deck? That would certainly save wear and tear on your fingers (or at least your cut-and-paste keys), and since WAP is supposed to be optimized for low bandwidth, it's a waste of time to have to send all that duplicated information. As you might have guessed, the `<template>` element allows this, too

### **WML Text and Text Formatting**

By this point, you have seen how to create all sorts of interactive applications in WML and how to use variables, tasks, and events to do things that would require serious server-side processing in HTML.

Now that there aren't any exciting new features to cover, it's time to go back to simple text and see what can be done with it to make it more interesting. This is an area where WML is seriously lacking in comparison to HTML, which provides all sorts of features for changing the size, style, typeface, and color of text, as well as powerful support for tables.

#### **The `<p>` Element**

As you saw back in, the `<p>` element marks a paragraph of text in a WML card. All body text, user controls (such as `<input>` and `<select>` elements), and images must appear within a `<p>` element. Most browsers ignore any that fall outside a `<p>`, but some actually reject the deck and refuse to display it. The one exception to this rule is the `<do>` element, which may appear either inside or outside a `<p>`. (It's actually regarded as better style to leave it outside the `<p>`.)

Normally, the `<p>` element is used without attributes, which results in the text in the paragraph being left-aligned and wrapped into lines to fit on the screen. It can also take two attributes to control how the text is presented, assuming of course that the browser is able (and willing) to display text with different alignments or to display non wrapped text.

#### **The `<br>` Element**

The `<br>` element is one of the simplest in WML. It takes no attributes and is always specified as an empty-element tag, `<br/>`. It marks a line break in a paragraph of text: when the browser encounters a `<br/>`, it starts a new line.

You may ask what the difference is between using a `<br/>` to break lines:

### **Character Formatting**

The support for character formatting in WML is quite limited compared to HTML. There is no support for specifying the color or typeface of the text, size changes are limited to "bigger" or "smaller," and there's no guarantee that any of these choices will be honored anyway.

Support is provided through seven elements. None take any attributes, and their effect applies to all the text they enclose. The browser is free to ignore any or all these attributes if it chooses or if its screen display can't cope with them.

## Tables

Tables are one of the worst-supported features in WML, at least in browsers available at the time of writing. The reason for this is that displaying tables properly (as laid down in the WAP specifications) often requires a lot of screen space, which is at a premium on devices such as cell phones. For example, at least one browser currently available displays each cell of a table on a new line, with lines of \* characters to mark the places where rows should have started.

WML also doesn't allow user interface elements to appear in tables, except for anchored text (using the <a> or <anchor> elements). This makes it easier for those browsers that do support tables. You are, however, allowed images, text-style changes, and even line breaks.

## WML Images

This chapter is the last one in this book dealing with WML, before we get into WMLScript. Therefore, it's finally time to get around to the subject of images in WML.

Why have I put this topic so late in the book? Because images should not be your major concern when writing WML. Most modern web pages rely heavily on images, so most books on HTML cover images quite early. When writing WML, however, you should remember that most WAP browsers are limited in terms of their image support.

## The <img> Element

Images are put into a WML page using the <img> element. If you're familiar with HTML, you'll recognize this tag, and it's indeed used in a similar way. Keep in mind that some browsers lay out images inline with text, while others place images on separate lines.

## The WBMP Image Format

You may have noticed that all the examples of the <img> element in this book have used image names ending with *.wbmp*. This is a special image format used in WAP. In fact, it's the only image format most browsers support. All WAP browsers that support images must support WBMP, so it's the safest choice if you want to include images in your WML.

WBMP stands for *wireless bitmap*, and it's a simple image format. Forget things like color, or animation, or even compression. (Image formats such as GIF and JPEG are the two most common on web pages; they compress the data to make the files smaller and faster to download.) WBMP files store only two things about the image: its size and a block of pixels, each of which is either black or white. There may be future versions with more features, but at the moment black and white is all there is.

## UNIT - IV

### Implementing WAP Services:-

#### Introduction to WML Script

Now that you have reached this point in the book, you should have a good idea of the things that can be done with WML alone: static page layouts and simple user interaction. Until now, the only way you could have any complicated interactions would be with some sort of dynamic content on the server.

Although WML provides variables, tasks, and events to make interaction much cleaner and easier, there are some tasks that can't be done in WML alone. If data must be checked for validity, for instance to make sure that a phone number really looks like a phone number or to check that a credit card number has the right number of digits, this checking has to be done by something outside WML.

#### WML Script Data types, Variables, and Conversions

WML Script is a weakly typed language. This means you never specify the data type of a variable or the return type of a function. All expressions have a type internally, but WML Script itself converts values back and forth between the different types as required, so that you don't have to.

For example, the value 1234 is an integer, but if you pass it to the String .length ( ) library function, which expects a string, it's implicitly converted to the string "1234", the length of which is 4.

#### WML Script Operators and Expressions

Now that you know about WML Script's data types, it's time to see how they can be linked with operators to form expressions.

If you know such languages as C or Java, the operators in this section will be familiar to you. Some of them have subtle differences, however, which are usually linked to WML Script's dynamic typing. These differences will be pointed out as we encounter them.

#### Operand Conversions

Some operators can take values of more than one type. For example, the \* operator for multiplication can operate on either integers or floating-point numbers. WML Script also defines which conversions are done in these cases:

- Operators that always take the same type of operands simply convert the arguments to those types. If the conversion fails, the result of the operation is invalid.
- Operators that take operands of any type simply use the values as they are. No conversion is performed because none is needed.

#### Assignment Operators

Having expressions isn't much use unless you can assign them to variables, and assigning to variables is the purpose of the assignment operators. The left side of any assignment operator must be the variable to assign.

The most common assignment operator is the simplest, which simply assigns an expression to a variable. It's represented by =.

## Arithmetic Operators

WML Script provides all the normal arithmetic operators. The syntax for these is exactly the same as in C or Java.

The simplest two arithmetic operators are unary plus, represented by +, and unary minus, represented by -. Unary plus simply converts the value to a number,<sup>[1]</sup> and unary minus converts the value to a number, then negates it (subtracts it from zero).

If it's already a number, no conversion is required. The phrase "convert to a number" really means "convert to a number if it isn't one already."

## Bitwise Operators

In addition to the normal arithmetic operators, WML Script provides four operators for performing Boolean arithmetic on the bits that make up integers. These operators all operate only on integers, so if any operand can't be converted to an integer, the result of the operation is invalid.

Bitwise *complement* (also called bitwise *not*) flips every bit in its argument. (Every 0 bit becomes 1, and every 1 bit becomes 0.) It's represented by the ~ operator.

## Shift Operators

As well as these operators to change individual bits, WML Script also provides shift operators, which allow you to move all the bits in an integer left or right. Because of the way integers are represented, these can be used to multiply or divide integers by a power of two.

Shift right has two operators, >> and >>>. The difference between these two is that >> handles negative numbers properly, so you can always use it to do division by powers of two. On the other hand, >>> treats all numbers as unsigned, even though all integers in WML Script are signed, and because of this it doesn't work as you'd expect for negative numbers. It's most often used, like the &, |, and ^ operators, when you use an integer just to store 32 separate bits, rather than a standard integer.

## Logical Operators

The bitwise operators are all useful in their place, but far more often you just want a simple Boolean *and* or *or* operator that converts its operands to Boolean values rather than integers.

These operators (called *logical* operators to distinguish them from the bitwise operators) also perform *short-circuit evaluation*. This means that they evaluate their left operand first, and if that is enough to tell the final result, the right operand isn't evaluated.

## Increment and Decrement Operators

WML Script provides four operators as a conveniently short form for the common task of adding or subtracting one from a variable.

## Comparison Operators

WML Script provides the standard six comparison operators: *equal to* represented by ==, *not equal to* represented by !=, *less than* represented by <, *less than or equal to* represented by <=, *greater than* represented by >, and *greater than or equal to* represented by >=.

Expression the *equal to* comparison is the classic gotcha of C-like languages. You need to be careful to write == rather than = if you mean the "equal to" comparison operation. If by mistake you write:

```
if (a = b)
```

rather than:

```
if (a == b)
```

the result is still a valid WML Script statement! However, rather than comparing a and b, it copies b into a and then tests if a can be converted to Boolean true. This can lead to some subtle bugs, so be careful.

## Type Operators

By now, you've heard a lot about the different data types WML Script provides and how it converts among these as necessary.

There are occasions where you may want to find the exact data type of a value, or at the very least check whether it's invalid or not. (Invalid usually represents some sort of error condition, so this last check is often equivalent to checking whether some operation went well.)

## The Conditional Operator

The conditional operator in WML Script selects between two sub expressions depending on the result of a condition expression. Its syntax is:

*Condition-expression? True-expression: false-expression*

## The Comma Operator

The, operator in WML Script isn't used very often. Its effect is to evaluate its left operand, throw away the result, and then evaluate its right operand. The result of the, operator is simply its right operand.

This behavior may seem bizarre if you haven't come across this operator before. It's used only when the left operand has some sort of side effect (such as an assignment to a variable or a function call). The most common use is in the initialize and increment sections of a for loop.

## Precedence and Associativity

Like most programming languages, WML Script assigns a level of *precedence* to each of the operators. In addition, each binary operator has an *associativity*. These exist to disambiguate expressions without the need for lots of extra parentheses.

The precedence determines which parts of an expression are evaluated first when there are different operators involved. For example, the \* operator has a higher precedence than the + operator, so:

## WML Script Statements

This chapter covers WML Script statements, which provide such useful control structures as loops and conditions, as well as simpler features such as the ability to return a value from a function.

Almost all of these features are similar to those found in languages such as C and Java, except that WML Script doesn't provide quite the same rich selection. For example, there is no switch statement, and none of the extra statements found in Java are present in WML Script.

## Expressions as Statements

Any WML Script expression can be turned into a statement by simply following it with a semicolon. This means that the expression is evaluated, but its result is thrown away. Any side effects of the expression still occur, however. The most common types of expressions to use as statements are the various assignments. (These are used far more often as statements than as expressions.)

## Blocks of Statements

Another simple type of statement is the block statement. This is simply a number of statements collected together and surrounded with curly braces. These are often used with if statements and while and for loops, to allow the parts of the if or the body of the loop to contain more than one statement.

## Conditions statements

Conditional statements in WML Script behave just like they do in C. The simplest form looks like:

```
if (condition)  
    statement-when-true
```

## Loops

As well as conditions with if and else, WML Script provides looping constructs. There are two types: for and while. Both behave very much as they do in C.

A while loop executes its body while a condition is true. If the condition is false at the start, the body is never executed. (As with if, failure to convert to Boolean is taken as false.) It looks like:

## Returning from a Function

The return statement ends execution of the current function. It has two forms:

```
return;
```

## Other Statements

Variable declarations with var are considered statements in WML Script; so they can appear anywhere that a statement can. You don't have to stick them all at the top of a function as you do in some languages. For example:

```
foo ();  
var x = 0105;
```

bar (x);

## WML Script Functions

You've now seen nearly all the elements that make up WML Script, but one thing that hasn't yet been properly covered is how you wrap these bits up into functions that can be called from WML.

That process is covered in this chapter, together with how you can put commonly used WML Script functions into a single library and call these from different places.

## Function Declarations

Already discuss.

## Function Calls

Function calls in WMLScript look just like they do in C or Java:

*function-name (argument-list)*

## Calls to Other Script Units

To call a function in another file, you must specify the external file in the call:

*file-identifier #function-name (argument-list)*

## Calling WML Script from WML

At last, here's the part that tells you how to actually get the browser to call all this WMLScript you've been writing!

A function to be called from WML must be declared extern. However, there are no other restrictions on it. It can have as many arguments as you like, and these arguments can be of any type.

## Standard Libraries

If you find yourself regularly using the same functions in different WML Script code, you can put them into a library. Simply put them all in the same file and declare them all extern. They can then be accessed from all your WML Script code using a url pragma and an external function call, as described earlier in this chapter.

In addition to these user-defined libraries, WML Script provides libraries that are built into the browser itself, not written in WML Script. They can do tasks no program written purely in WML Script can do. (Think of these as being a bit like system calls in a normal programming language.) These libraries are called *standard libraries*, to differentiate them from user-defined libraries written in WML Script.

## WML Script Pragmas

This chapter discusses the features of WML Script known as *pragmas*, which specify meta-information about a WML Script unit, in a similar way to the <meta> and <access> elements for WML files. You have already encountered one pragma, the url pragma for referencing other WML Script units. In addition, there is an access pragma, corresponding to WML's <access> element, and a meta pragma, corresponding to the <meta> element. These pragmas are processed by the WAP gateway to control the headers sent along with the compiled unit.



## The access Pragma

The access pragma provides the same simple access control as the <access> element does for WML decks. That is, it specifies a domain and path that must match the URL of the caller for a call to be permitted.

There are three forms:

## The meta Pragma

The meta pragma allows arbitrary meta-information to be included in a WML deck. There are three variations on it:

use meta name *name value scheme*;  
use meta http equiv *name value scheme*;  
use meta user agent *name value scheme*;

## The Lang Library

The Lang standard library contains simple functions that extend the core functionality of WMLScript. This includes functions for explicitly converting strings to integers and floating-point numbers, for generating random numbers, and for determining various constants related to the WMLScript interpreter.

## The Float Library

The Float standard library contains functions for operating on floating-point numbers, including simple operations for converting to integers, as well as more complicated functions such as square root.

Some WMLScript interpreters don't support floating-point operations at all. If this is the case, all functions in this library return invalid, regardless of their arguments.

## The String Library

The String standard library contains routines for string manipulation. This includes functions for extracting individual characters from strings, for finding the lengths of strings, and also for treating strings as arrays of values and operating on them on this basis.

It's important to note that none of these functions actually changes the strings passed as arguments. Functions that claim to modify strings simply return a new string with the modification. The original is always unchanged.

## The URL Library

The URL standard library contains functions for parsing URLs, both relative and absolute. See **Appendix A**, for more on URLs and their different forms.

## The WML Browser Library

The WML Browser standard library provides functions that allow WMLScript code to interact with the browser context.

At some point, there may be a way for something other than WML to invoke WMLScript functions. (This isn't the case at the time of writing, however.) If the WMLScript interpreter isn't invoked from a WML browser, each function in this library returns invalid and has no other effect.

## The Dialogs Library

The Dialogs standard library contains functions for putting up simple dialogs for communicating with the user.

## **TEXT BOOKS**

[T1] Jochen Schiller, “Mobile Communications”, PHI/Pearson Education, Second Edition, 2003.

[T2] Sandeep Singhal, “The Wireless Application Protocol, Writing Applications for Mobile Internet”, Pearson Education, 2000

[T3] Learning WML, and WMLScript, Programming the Wireless Web, Martin Frost, Publisher: O'Reilly 2000

## **REFERENCE BOOKS**

[R1] William Stallings, “Wireless Communications and Networks”, PHI/Pearson Education, 2002

[R2] Theodore S Rappaport, “Wireless Communication Principles and Practice”, 2nd Ed, Pearson Education. 2002

[R3] C. Y. Lee and William, “Mobile Cellular Telecommunications”, 2nd Ed, McGraw Hill. 2001



तेजस्वि नावधीतमस्तु  
ISO 9001:2008 & 14001:2004

**FAIRFIELD**  
**Institute of Management & Technology**  
Managed by 'The Fairfield Foundation'  
( Affiliated to GGSIP University, New Delhi )